

# Energy Efficient 3 Phase LV Induction Motors



Catalogue 2014



**HAVELLS-LAFERT** MOTORS





HAVELLS CAFETERIA

# About us

**H**avells India Ltd is a billion-dollar-plus organization, and is one of the largest & India's fastest growing electrical and power distribution equipment manufacturer with products ranging from Industrial & Domestic Circuit Protection Switchgear, Cables & Wires, Motors, Fans, Power Capacitors, CFL Lamps, Luminaires for Domestic, Commercial & Industrial applications, Modular Switches, & Bathfittings covering the entire gamut of household, commercial and industrial electrical needs.

Havells owns some of the prestigious global brands like Crabtree, Sylvania, Concord, Luminance, Linolite, & SLI Lighting.

With 91 branches / representative offices and over 8000 professionals in over 50 countries across the globe, the group has achieved rapid success in the past few years. Its 11 state-of-the-art manufacturing plants in India located at Haridwar, Baddi, Noida, Sahibabad, Faridabad, Bhiwadi, Alwar, Neemrana, and 10 state-of-the-art manufacturing plants located across Europe, Latin America & Africa churn out globally acclaimed products. Havells is a name synonymous with excellence and expertise in the electrical industry.

To add to the existing state-of-the-art manufacturing plants, Havells has now started a world class Motor Plant at Neemrana (Rajasthan). It is one of the largest LV Motor Plant in Asia spread over 42 acres land and where we manufacture energy efficient motors ranging from 0.12HP to 470HP.

The plant has a capacity of manufacturing over 20000 motors per month. The state-of-the art plant and machinery has been imported from AEG Spain.

The Manufacturing Strengths of the Plant are :

- In house manufacturing of complete range of motors from 56-355 frame
- Automatic winding lines from 56-250 frame
- Automatic impregnation plant
- Vacuum impregnation plant
- Fully Automated temperature controlled paint stations
- Modern Automatic Type Test Plant
- Mechanical Test Lab

Havells is committed to manufacturing excellence and providing world class quality products at affordable prices. Havells offers a complete solution which is not only safe and reliable but also saves energy. We will continue the same tradition with our motors also.

## Manufacturing Process



Shaft Machining



Rotor Run Out



Automatic Winding



Automatic Impregnation Plant



Assembly Line



Testing

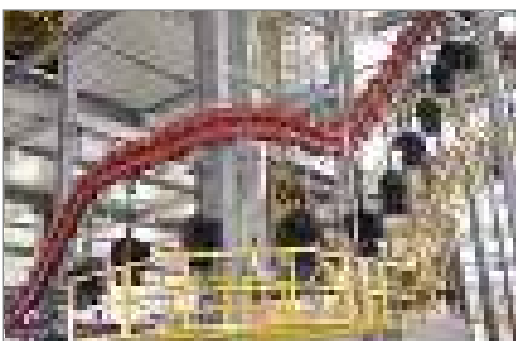

Conveyorised Painting



Finished Product

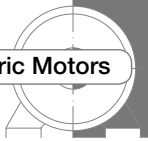

## Contents

	<b>Page</b>
<b>Standard product specification</b> .....	2
<b>Indian &amp; International standards</b> .....	3
<b>General</b>	
Conditions of installations .....	4
Material .....	4
Tolerances (Electrical) .....	5
Mounting Arrangement .....	6
Degree of Protection .....	7
Effect of Variation of Voltage & Frequency .....	8
Overload .....	8
Insulation class and temprature rise .....	8
Installation at higher altitudes .....	9
Permissible starts .....	9
Motor for 60Hz Operation .....	10
Inverter duty operation .....	10
<b>Electrical Design</b>	
Connection diagrams .....	11
Electrical parameters .....	12
Electrical parameters .....	13
Speed Torque Characteristics .....	14
Starting methods .....	15
Thermal protection .....	16
Space heaters .....	17
Enclosure details .....	17
<b>Mechanical Design</b>	
Spare part description .....	18
Bearing details .....	19
Pulley diameter .....	19
Axial force .....	19
Permissible radial forces .....	20
Bearing Lubrication and maintenance .....	21
Permissible operating speed .....	21
Belt drive .....	21
Noise level .....	22
Vibration level .....	22
Terminal box .....	23
Cable size .....	23
Testing .....	24
Order data .....	25
<b>Technical Data</b> .....	26-32
<b>GA Drawing</b> .....	33-35
<b>Terminal Box Drawing</b> .....	36-40
<b>Shipping dimensions</b> .....	41

## STANDARD PRODUCT SPECIFICATIONS

Motor Type	AC Three Phase Squirrel Cage Induction Motor
Reference Standard	IS: 325 / IS:12615
Voltage $\pm$ Variation	415 Volts $\pm$ 10%
Frequency $\pm$ Variation	50 Hz $\pm$ 5%
Combined Variation	10% (Absolute Sum)
Enclosure	TEFC
Mounting	Foot, Flange, Foot cum Flange, face, Foot cum Face
Frame Dimensions	As per IS 1231 & IS 2223
Altitude	Upto 1000M
Relative Humidity	Upto 100%
Degree of Protection	IP 55 (As per IS 4691)
Class of Insulation	Class 'F'
Ambient Temp / Temp Rise	50°C / 70°C
Duty / Rating	S1 / Continuous
Position of Terminal Box	Top
Connection / No. of Leads	Up to 2 HP-STAR /6 Leads & 3 HP delta / 6 Leads
Direction of Rotation	Bi-directional
Grease Type	Lithium Based Grease
Greasing Arrangements	Online greasing arrangement in 180 and above frame
Cooling	Shaft Mounted Fan
Paint	RAL 9005
	<b>Range</b>
Output	0.12-470 HP conforming to IS: 325
Voltage	220-660V
Frequency	25-60Hz
Ambient temperature	20deg C - 50deg C



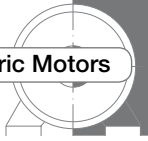

## Indian Standard for Electric Motors

The motors comply with the relevant standards and regulations;

### Indian standards

IS 325:	1996	:Three phase induction motors
IS 900:	1992	:Code of Practice for installation and maintenance of induction motors
IS 1231:	1974	:Dimensions of three phase foot mounted AC induction motors
IS 2223:	1983	:Dimensions of flange mounted AC induction motors
IS 2253:	1974	:Designations for types of construction and mounting arrangements of rotating electrical machines
IS 2254:	1985	:Dimensions of vertical shaft motors for pumps.
IS 2968:	1968	:Dimensions of slide rails for electric motors
IS 4029:	1967	:Guide for testing three phase induction motors
IS 4691:	1985	:Degree of protection provided by enclosures for rotating electrical machinery
IS 4722:	1992	:Rotating electrical machines
IS 4728:	1975	:Terminal Marking and direction of rotation for rotation electrical machinery.
IS 4889:	1968	:Methods of determination of efficiency of rotating electrical machines
IS 6362:	1995	:Designation of methods of cooling for rotating electrical machines
IS 7538:	1996	:Three phase squirrel cage induction motors for centrifugal pumps for agricultural applications
IS 7816:	1975	:Guide for testing insulation resistance of rotating machines
IS 8151:	1976	:Single speed three phase induction motors for driving lifts
IS 8789:	1996	:Value of performance characteristics for three phase induction motors.
IS 12065:	1987	:Permissible limits of noise levels for rotating electrical machines
IS 12075:	1986	:Mechanical vibration of rotating electrical machines, measurement, evaluation and limits of vibration severity
IS 12615:	2004	:Energy efficient three-phase –motors
IS 13529:	1992	:Guide on effects of unbalanced voltage on the performance of three phase induction motors
IS 13555:	1993	:Guide for selection and application of three-phase AC induction motors for different types of driven equipment.

## GENERAL

### Conditions of installation

The motors conform to degree of protection IP 55 as per IS 4691 / IEC 60034-5. Higher protection on request.

The standard design for horizontal mounting is suitable for indoor and protected outdoor installation (temperature of coolant -20° to + 50°C).

For unprotected outdoor installation or severe climatic conditions (moisture category wet, climate group WORLDWIDE, extremely dusty site conditions, aggressive industrial atmosphere, danger of storm rain and coastal climate, danger of attack by termites, etc.), as well as vertical mounting, special protective measures are recommended, such as:

- Protective cowl (for vertical *shaft-down* motors)
- For vertical *shaft-up* motors additional bearing seal and flange drainage
- Special paint finish
- Treatment of winding with protective moisture-proof varnish
- Anti-condensation heating (possibly winding heating)
- Condensation drain holes

The special measures to be applied have to be agreed with the factory once the conditions of installation have been settled.

**The corresponding conditions of installation have to be clearly indicated in the order.**

### Material

Motor parts	Frame size	Material
Stator frame	56 - 160	Aluminum alloy
	80 - 355	Cast iron
Endshield	56 - 112	Aluminum alloy
	80 - 355	Cast iron
Flanged endshield	56 - 112	Aluminum alloy
	80 - 355	Cast iron
Fan cover	56 - 71	Industrial nylon grade
	63 - 355	Sheet steel
Fan	56 - 355	Industrial nylon grade
Terminal box	56 - 71	Industrial nylon grade
	63 - 160	Aluminum alloy
	160 - 355	Sheet steel / Cast iron



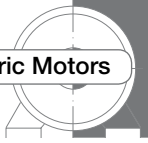

## Tolerances

For industrial motors conforming to IS 325 / IEC 60034-1, certain tolerances must be allowed on guaranteed values, taking into consideration the necessary tolerances for the manufacture of such motors and the materials used. The standard includes the following remarks:

1. It is not intended that guarantees necessarily have to be given for all or any of the items involved. Quotations including guaranteed values subject to tolerances should say so, and the tolerances should be in accordance with the table.
2. Attention is drawn to the different interpretation of the term guarantee. In some countries a distinction is made between guaranteed values and typical or declared values.
3. Where a tolerance is stated in only one direction, the value is not limited in the other direction.

## Electrical Tolerances

Values for	Tolerance
Efficiency ( $\eta$ ) (by indirect determination)	- 0.15 (1 - $\eta$ ) at $P_N^* \leq 50$ kW - 0.1 (1 - $\eta$ ) at $P_N^* > 50$ kW
Power factor ( $\cos \phi$ )	$-\frac{1 - \cos \phi}{6}$ , minimum 0.02, maximum 0.07
Slip (s) (at rated load and at working temperature)	$\pm 20$ % of the guaranteed slip at $P_N \geq 1$ kW $\pm 30$ % of the guaranteed slip at $P_N < 1$ kW
Breakaway starting current ( $I_A$ ) (in the starting circuit envisaged)	+ 20 % of the guaranteed starting current (no lower limit)
Breakaway torque (MA)	- 15 % and + 25 % of the guaranteed breakaway torque (+ 25 % may be exceeded by agreement)
Pull-up torque (MS)	- 15 % of the guaranteed value
Pull-out torque (MK)	- 10 % of the guaranteed value (after allowing for this tolerance, $M_K/M_N$ not less than 1.6)
Moment of inertia (J)	$\pm 10$ % of the guaranteed value

\*  $P_N$  = Rated Power.

### Mounting arrangements

Mounting arrangements for rotating electrical machines are designated according to IS 2253 / IEC 60034-7. Our motors are available with the mounting arrangements listed below, depending on design and frame size. Motors with aluminium frame are equipped with detachable feet that allow easy change of mounting arrangement.

#### Foot mounting

B3 - Horizontal foot mounted

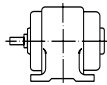

B6 - Horizontal wall mounted (LHS)



B7 - Horizontal wall mounted (RHS)



B8 - Horizontal ceiling mounted



V5 - Wall mounted shaft down wards

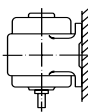

V6 - Wall mounted shaft up wards

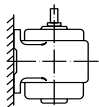

B34 - Horizontal base flange type 'C'

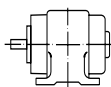

#### Flange mounting

B5 - Flange type 'D'

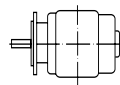

V1 - Vertical down wards flange type 'D'

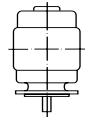

V3 - Vertical up wards flange type 'D'

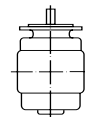

B35 - Horizontal base flange type 'D'

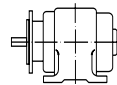

B14 - Horizontal face flange type 'C'

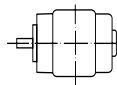

V18 - Vertical face down wards flange type 'C'

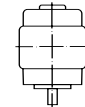

V19 - Vertical face up wards flange type 'C'

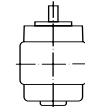

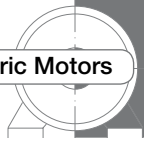

It is essential to state the desired mounting arrangement when ordering, as the constructive design depends partly on the mounting arrangement.

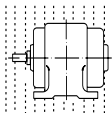
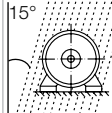
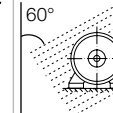
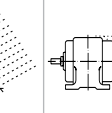
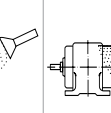
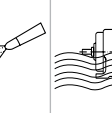

### Degree of protection

Degrees of protection for mechanical machines are designated in accordance with IS 4691 / IEC 60034-5 by the letters IP and two characteristic numerals.

							
First numeral: Protection against contact and ingress of foreign bodies 	No. special protection	Protection against vertically falling water drops	Protection against dropping water when inclined by up to 15 degrees	Protection against water spray when inclined by up to 60 degrees from vertical	Protection against water splashed from any direction	Protection against water projected by nozzle from any direction	Protection against heavy seas
Second Numeral : Protection against ingress of water 	0	1	2	3	4	5	6
0	No special protection						
1	Protection against solid foreign bodies > 50 mm (Example: inadvertent contact with hand)						
2	Protection against solid foreign bodies > 12 mm (Example: inadvertent contact with the fingers)	IP 21	IP 22	IP 23			
3	Protection against solid foreign bodies > 2.5 mm (Example: Inadvertent contact with wire & tools)						
4	Protection against solid foreign bodies > 1 mm (Example: Inadvertent contact with wire, bands)				IP 44		
5	Protection against dust (Harmful deposits of dust)				IP 54	IP 55	IP 56

**Effect of variation of voltage and frequency on the characteristics of motor**

Characteristics	Voltage		Frequency	
	110%	90%	105%	95%
<b>Torque</b> Starting & Maximum	Increase 21%	Decrease 19%	Decrease 10%	Increase 11%
<b>Speed</b> Synchronous Full Load	No Change Increase 1%	No Change Decrease 1.5%	Increase 5% Increase 5%	Decrease 5% Decrease 5%
<b>Current</b> No Load Starting Full Load Temp. Rise Overload Capacity Magnetic Noise	Increase 10-15% Increase 10-12% Decrease 7% Decrease 3-4% Increase 21% Slight Increase	Decrease 10-12% Decrease 10-12% Increase 11% Increase 6-7% Decrease 19% Slight Decrease	Decrease 5-6% Decrease 5-6% Slight Decrease Slight Decrease Slight Decrease Slight Decrease	Increase 5-6% Increase 5-6% Slight Increase Slight Increase Slight Increase Slight Increase
<b>Efficiency</b> Full Load	Increase 0.5-1.0%	Decrease 2%	Slight Increase	Slight Decrease
<b>Power Factor</b>	Decrease 3%	Increase 1%	Slight Increase	Slight Decrease

**Overload**

At operating temperature three-phase motors are capable of withstanding an overload for 15 seconds at 1.6 times the rated torque at rated voltage. This overload is according to IS 325 / IEC 60034-1 and will not result in excessive heating.

**Insulation and temperature rise**

Motors are manufactured with class 'F' insulation as a standard and temperature rise limited to class 'B'.

The motors are suitable for an ambient temperature of 50°C and temperature rise limited to 70°C.

Temperature rise ( $\Delta T^*$ ) and maximum temperatures at the hottest points of the winding ( $T_{max}$ ) according to the temperature classes of IEC 60034-1 / IS 325.

	$\Delta T^*$	$T_{max}$
Class B	70°C	130°C
Class F	95°C	155°C
Class H	115°C	180°C

\*Measurement by resistance method.

Output reduction at ambient temperatures over 50°C

Ambient temperature	50°C	55°C	60°C
Reduction of nominal output to approx.	100%	95%	90%

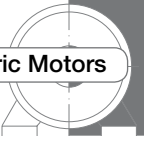

### Installation at altitudes of more than 1000 m above sea level

Altitude of installation	2000 m	3000 m	4000 m
At 50°C ambient temperature and thermal class B			
Rated output reduced to approx.	92%	84%	76%
At 50°C ambient temperature and thermal class F			
Rated output reduced to approx.	89%	79%	68%
Full nominal output to data tables with thermal class B			
and ambient temperature of	32°C	24°C	16°C
Full nominal output to data tables with thermal class F			
and ambient temperature of	30°C	19°C	9°C

### Motors for 60 Hz operation

Motors wound for a certain voltage at 50 Hz can be operated at 60 Hz, without modification, subject to the following changes in their data.

Motor wound for 50 Hz and	Connected to 60 Hz and	Data at 60 Hz in percentage of values at 50Hz						
		Output	rpm	$I_N$	$I_S / I_N$	$T_N$	$T_S / T_N$	$T_{MAX} / T_N$ 1)
220 V	220 v	100	120	98	83	83	70	85
	225 v	115	120	100	100	96	95	98
380 V	380 V	100	120	98	83	83	70	85
	415 V	110	120	98	95	91	85	93
	440 V	115	120	100	100	96	95	98
	460 V	120	120	100	105	100	100	103
400 V	380 V	100	120	100	80	83	66	80
	400 V	100	120	98	83	83	70	85
	415 V	105	120	100	88	86	78	88
	440 V	110	120	100	95	91	85	93
	460 V	115	120	100	100	96	95	98
	480 V	120	120	100	105	100	100	100
415 V	415 V	100	120	98	83	83	70	85
	460 V	110	120	98	95	91	85	94
	480 V	115	120	100	100	96	95	98
500 V	500 V	100	120	98	83	83	70	85
	550 V	110	120	98	95	91	85	94
	575 V	115	120	100	100	96	95	98
	600 V	120	120	100	105	100	100	103

Efficiency, power factor and temperature rise will be approximately the same as at 50 Hz.

- 1)
- $I_N$  = rated current N
  - $I_S / I_N$  = starting current/rated current S N
  - $T_N$  = rated torque N
  - $T_S / T_N$  = maximum torque/rated torque max N
  - $T_{MAX} / T_N$  = starting torque/rated torque

### Motors for inverter duty operation (frequency converter)

The motors frame sizes 90 upwards in standard design are suitable for operation on static frequency converters, taking into account the following remarks:

- Maximum converter output voltage 500V at peak voltages  $\hat{U}$  1460V and  $du/dt$  13 kV/us. For higher converter output voltages or stresses, a special insulation is required.
- With square characteristic of the load torque, motors can be driven with their rated torque.
- For constant torque, the rated torque of motors with internal cooling must be reduced due to reduced cooling air inlet. Depending on the control range, the use of an external fan would be advisable.
- Insulated or hybride bearings may be necessary on critical applications. We generally recommend the use of insulated bearings for motors frame size 280 upwards.
- The motors of frame size 56 – 80 can be operated on single-phase converters up to maximum 60 Hz.
- Depending on the operating point and converter type, converter-fed motors produce between approx. 4 - 10 dB(A) higher noise values than when supplied from the mains. For motors driven with a frequency over 50 Hz, more fan noise is produced. We recommend the use of an external fan.

## ELECTRICAL DESIGN

### Connection diagrams

Windings of standard three-phase motors can be connected either in star or delta connection.

#### Star connection

A star connection is obtained by connecting W2, U2, V2 terminals to each other and the U1, V1, W1 terminals to the mains. The phase current and voltage are:  
 $I_{ph} = I_n$  ;  $U_{ph} = U_n / \sqrt{3}$

where  $I_n$  is the line current and  $U_n$  the line voltage referred to the star connection.

#### Delta connection

A delta connection is obtained by connecting the end of a phase to the beginning of the next phase.

The phase current  $I_{ph}$  and the phase voltage  $U_{ph}$  are:

$$I_{ph} = I_n / \sqrt{3} ; U_{ph} = U_n$$

where  $I_n$  and  $U_n$  are referred to the delta connection.

#### Star-delta starting

Star-delta starting allows a peak current reduction, ensuring however that the peak torque obtained is bigger than the resistant torque. Actually, it should be noted that the torque of an induction squirrel-cage motor is directly proportional to the square of the voltage. Motors whose rated voltage with delta connection corresponds to the mains voltage, can be started with the star-delta method.

All motors can be supplied with windings designed for star-delta starting (for example: 415 V  $\Delta$  / 690 Volts Y).

#### Pole-changing motors

Standard pole-changing motors are designed for single voltage and direct-on-line starting (special design for Y- $\Delta$ -connection on request).

When the ratio between the two speeds is from 1 to 2, the standard motors have one single winding (Dahlander connection). For the other speeds, the motors have two separate windings.

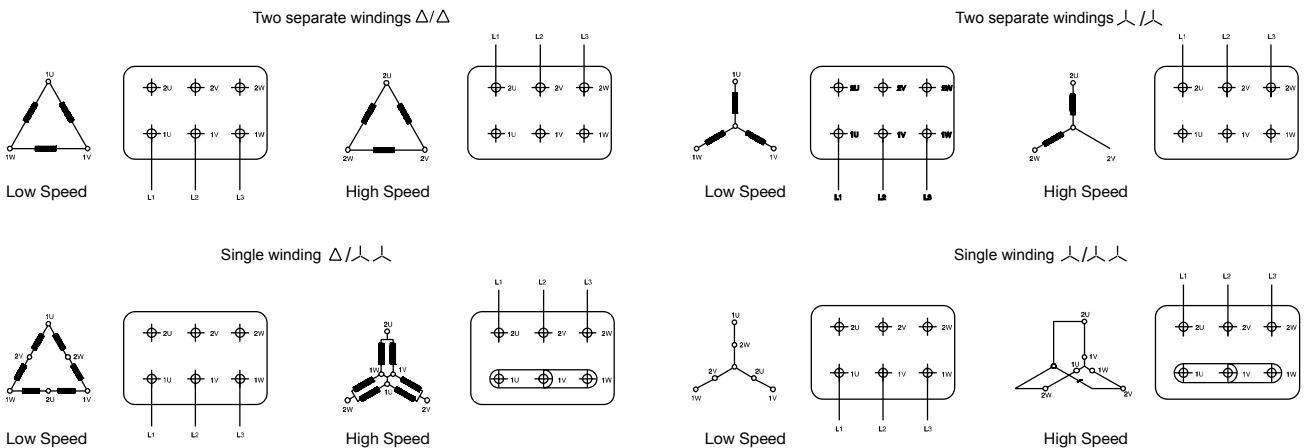
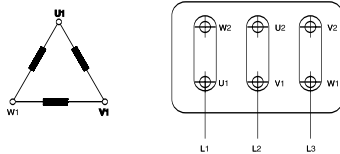
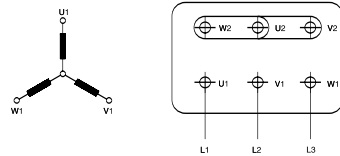

**Electrical Parameter**

**Rated voltage**

Motors are suitable for variation of ± 10% of the rated voltage. Therefore the motors are designed for the following rated voltage ranges (exceptions are shown in the data tables):

- Rated voltage
- 230 V ±10%
- 415 V ±10%
- 690 V ±10%

Within the rated motor voltage range, the permissible maximum temperature is not exceeded. When the motors are operated at the limits of the voltage tolerance, the permissible over temperature of the stator winding may be exceeded by 10 °C.

For motors in 500 V, 50 Hz design, as well as all abnormal voltages, no voltage range is marked. The voltage tolerances to IS 325 / IEC 60034-1 apply.

**Rated frequency**

Motors are suitable for 50 Hz with a variation 5%. 50 Hz motors can also be operated on 60 Hz mains, provided the mains voltage increases proportionally to the frequency. The relative values for starting and breakaway torque remain nearly unchanged and slightly increase for the starting current. The rated speed increases by the factor 1.2 and output by factor 1.15. Should a motor designed for 50 Hz be operated at 60 Hz without the voltage being increased, the rated output of the motor cannot be increased. Under these operating conditions, rated speed increases by factor 1.2. The relative values for starting and breakaway torque are reduced by factor 0.82 and for starting current by factor 0.9 Frame.

**Rated current I<sub>N</sub>**

The rated currents listed in the data tables apply to an operating voltage of 415V. The conversion to other operating voltages, with output and frequency remaining unchanged, is to be made as follows:

Nominal voltage (V)	230	380	415	440	500	660	690
Conversion factor x I <sub>N</sub>	1.74	1.05	1.0	0.91	0.80	0.61	0.58

**Rated torque**

$$\text{Rated torque in Nm} = 9550 \times \frac{\text{Rated power in kW}}{\text{Rated speed in RPM}}$$

**Output**

The outputs stated in this catalogue are for constant load in continuous running duty S1 according to IS 325 / IEC 60034-1, based on an ambient temperature of 50° C and installation at altitudes up to 1000 m above sea level.

For severe operating conditions, e.g. high switching rate, long run-up time or electric braking, a thermal reserve is necessary, which could call for higher thermal class or the use of a motor with a higher rating. In these cases we recommend to enquire with detailed information on the operating conditions.



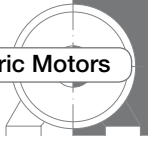

## Number of poles

Number of poles of the motor determine the basic speed (synchronous speed) of the motor. Standard motors are available in the configuration of 2,4,6 and 8-poles.

## 5. Power

Rated power is the shaft power of the motor with an ambient temperature not exceeding 45°C/50°C and an altitude not exceeding 1000m above mean sea level.

## 6. Rated speed, slip

Rated speed corresponds to the operating speed of the motor at the rated power when it is being fed at rated voltage and frequency.

The synchronous speed of an induction motor depends on the supply frequency and the number of poles of the stator winding.

Thus,

$$\eta_s = f/p \times 120(\text{rpm})$$

where  $\eta_s$  = synchronous speed (rpm) s

f = frequency (Hz)

P = number of poles

note 2p = number of poles

The rated speed given in the list is for motors operating at rated power under normal voltage and frequency.

The difference between synchronous speed,  $\eta_s$  and rotor speed,  $\eta_r$ ; referred to the synchronous speed, is called slip.

This slip, s, is expressed as a percentage;

$$s = \frac{\eta_s - \eta_r}{\eta_s} \times 100 (\%)$$

When the motor is partly loaded the slip varies almost linearly with the load.

## Starting current

Usually, given as a percentage or as a multiple of rated current, it is the value of the current drawn by the motor during starting.

The value of the starting current is generally between 500-700% (5-7 per unit) of the rated current.

## Torque characteristics

Typical torque/speed characteristics of the motor is shown in figures on page no. 15 along with different relevant parameters.

The nominal torque of the motor  $T_N$  is the torque developed by the motor at rated speed, n while delivering rated power P. The relationship between the torque  $T_N$ , the power P, and  $n$

the speed n is

$$T_N = 9550 \times P/n \text{ [Nm]}$$

Where P = power (kW)

$T_N$  = motor speed (rpm)

alternatively, torque T, in kgm can be given as

$$T_N = 974 \times P/n \text{ [kgm]}$$

Starting torque of the motor  $T_s$  is the torque developed by the motor at zero speed when it is directly switched on.

Value of starting torque is usually given as a percentage or as a multiple of nominal motor torque  $T_N$ .

Pull out torque of the motor  $T_{max}$  is the maximum torque that the motor can develop when it is operated directly on line.

Value of pull out torque is usually given as a percentage or as a multiple of nominal motor torque  $T_N$ .

## Moment of Inertia

The moment of inertia J is given in Kgm<sup>2</sup>. The moment of inertia is numerically equal to 1/4 GD<sup>2</sup>. The moment of

inertia  $J_L$  of the driven machine at  $n_L$  rpm when referred to motor speed n rpm is given by  $J = J_L [n_L/n]^2$ .

## Overloads

In accordance with IS:325 motors are rated to withstand an overload, an excess torque of 60% of their rated torque at rated voltage and frequency for 15 seconds.

### Speed Torque Characteristics

Typical Speed Torque characteristics for few applications are shown below:

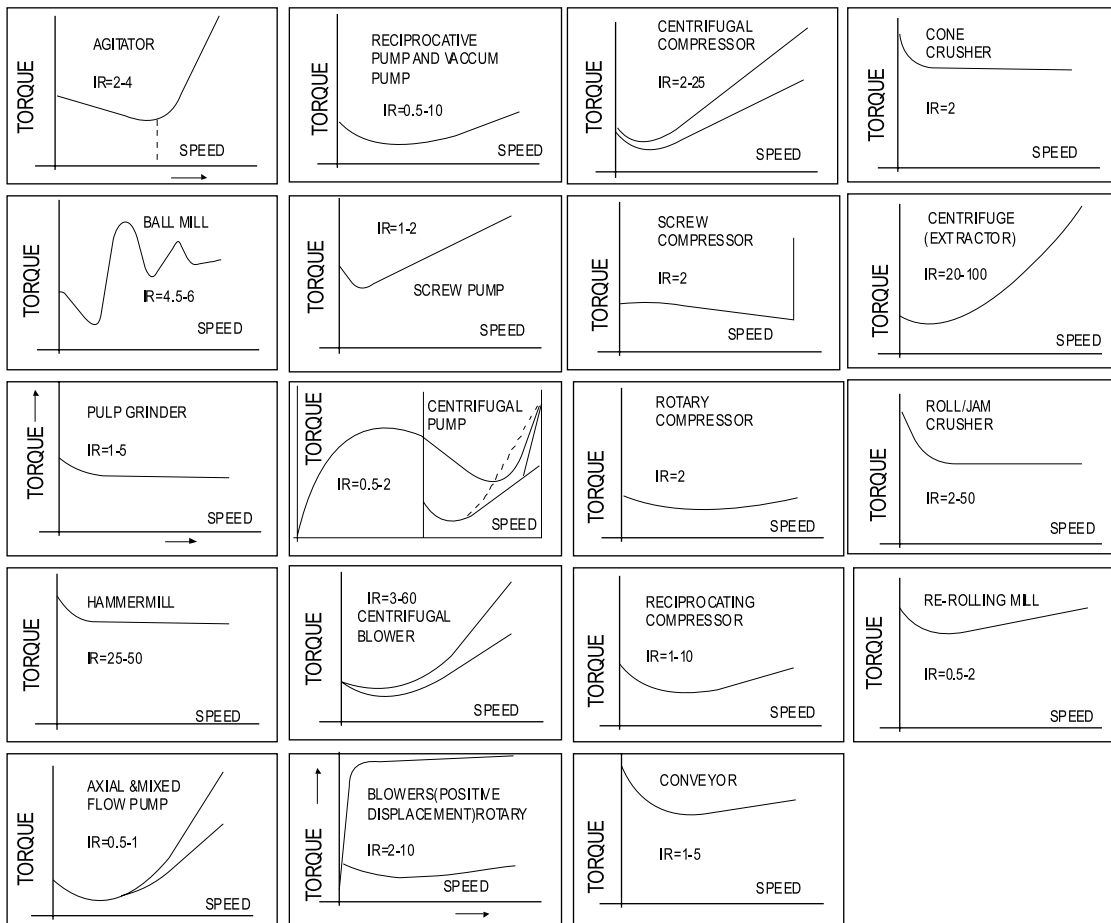

**Note:** These characteristics are exemplary and the values of Torque, Inertia Ratio etc. are given based on experience of normal applications. These values should be verified in actual before forming any reference.

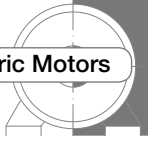

## Starting methods for AC motors

### Reducing electrical and mechanical stress at start-up

The starting current of an AC motor can vary from 3 to 7 times the nominal current. This is because a large amount of energy is required to magnetise the motor enough to overcome the inertia the system has at standstill. The high current drawn from the network can cause problems such as voltage drop, high transients and in some cases, uncontrolled shutdown. High starting current also causes great mechanical stress on the motor's rotor bars and windings and can affect the driven equipment and the foundations. Several starting methods exist, all aiming to reduce these stresses. The load, the motor and the supply network determine the most appropriate starting method. When selecting and dimensioning the starting equipment and any protective devices, the following factors must be taken into account:

- The voltage drop in the supply network when starting the motor
- The required load torque during start
- The required starting time

### Direct-on-line (DOL) start:

Direct on line starting is suitable for stable supplies and mechanically stiff and well dimensioned systems. It is the simplest, cheapest and most common starting method. Starting equipment for small motors that do not start and stop frequently is simple, often consisting of a hand operated motor protection circuit breaker. Larger motors and motors that start and stop frequently, or have some kind of control system, normally use a direct-on-line starter which can consist of a contactor plus overload protection, such as a thermal relay.

### Star-Delta (Y/D) starting:

Most low voltage motors can be connected to run at either 400V with delta connection or at 690V with star connection. This flexibility can also be used to start the motor with a lower voltage. Star/delta connection gives a low starting current of only about one third of that during direct-online starting, although this also reduces the starting torque to about 25%. The motor is started with Y-connection and accelerated as far as possible, then switched to D-connection. This method can only be used with induction motors delta connected for the supply voltage.

### Soft starters

Soft starters are based on semiconductors, which, via a power circuit and a control circuit, initially reduce the motor voltage, resulting in lower motor torque. During the starting process, the soft starter progressively increases the motor voltage so that the motor becomes strong enough to accelerate the load to rated speed without causing torque or current peaks. Soft starters can also be used to control the stopping of a process. Soft starters are less costly than frequency converters but like frequency converters, they may inject harmonic currents into the grid, disrupting other processes.

### Frequency converter start

Although a frequency converter is designed for continuous feeding of motors, can also be used exclusively for start-up only. The frequency converter enables low starting current because the motor can produce rated torque at rated current from zero to full speed. As the price of frequency converters continues to drop, they are increasingly replacing soft starters. However in most cases they are still more expensive than soft starters, and like these, they inject harmonic currents into the network.

### Thermal protection

The decision on a particular type of thermal protection should be taken according to the actual operating conditions. Motors may be protected by means of current-dependent thermal protection switches, over current relays and temperature detectors.

Thermal protection is possible as follows:

- Thermal protection switch with bimetal release
- Thermistor protection with semiconductor temperature detectors (PTC) in the stator winding in connection with release (if required, with additional motor protection switch).
- Bimetal temperature detector as N/C or N/O in the stator winding (if required, with additional motor protection switch).
- Resistance thermometer for monitoring winding and bearing temperature.

Should protection of the motor be required, we install protection switch with bimetal release up to frame size 112 and semiconductor temperature detectors in motors  $\geq 132$ .

Although there are motors available from stock with built-in semiconductor temperature detector, a special remark has to be made in the enquiry or order when motor protection is required.

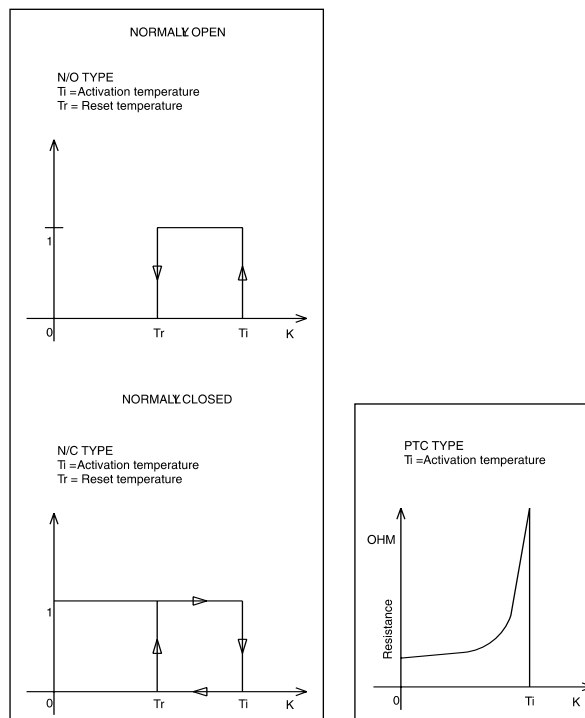

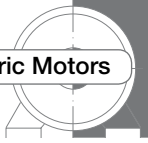

### Anti-condensation heater / space heaters

Space heaters are generally provided on the winding of motor to heat the windings when motor is kept in idle condition in order to prevent moisture or due settling over the windings and reducing insulation resistance.

Frame size	Supply voltage (V) (Single Phase)	Heater rating per motor (W)
112 - 160	240	25
180 - 225	240	40
250 - 280	240	60
315	240	60

*During operation of the motor, the heating must be switched off.*

### Other accessories

Motors can be supplied with the following accessory:

- Encoder with internal or external cooling

#### Encoder (standard design)

Supply voltage $U_B$	5 V
Pulses per revolution	500-2048
Outputs	2 signals with rectangular pulses A, B 2 signals with inverted rectangular pulses A, B zero pulse and inverted zero pulse
Maximum frequency	100 kHz
Maximum speed	3,000 (6,000) RPM
Temperature range	-20°C to + 85°C
Degree of protection	IP 55

### Enclosure

Frames 56 to 112 M are of diecast aluminum. Foot mounted stators have integral feet. TEFC & TE motors have integral longitudinal ribs for effective heat transfer.

The stator & end shields are machined to close tolerances for providing perfect alignment & fits.

Terminal boxes of frames up to 132M are of diecast aluminum alloy. Frame 160 & above have sheet metal/cast iron terminal box. All joints in terminal box are sealed with gaskets. Motors above frame 160 have drain holes at their lowest position as a standard features.

### Core

Both stator and rotor cores are made of high quality magnetic steel.

### Windings

Stator windings consists of modified polyester enamel covered copper wire. Motor with higher temperature windings wires can also be supplied as per customer requirement.

### Insulation

All motors are made with class F insulation as a standard feature.

The slot liners are either provided with double cuffing or edge binding at the slot mouth portion to strengthen the insulation. For frame 160 & above class F varnish is used for impregnating the winding. Epoxy gel coat can be provided as per requirement to withstand the electrical and mechanical stresses. Surge testing is carried out on all windings in addition to all other tests ensuring healthiness of windings.

### Rotor

The rotor of SCR motors are made of pressure diecast aluminum (or alloy in case of special designs) up to frame 355L.

## MECHANICAL DESIGN

### Spare Part description

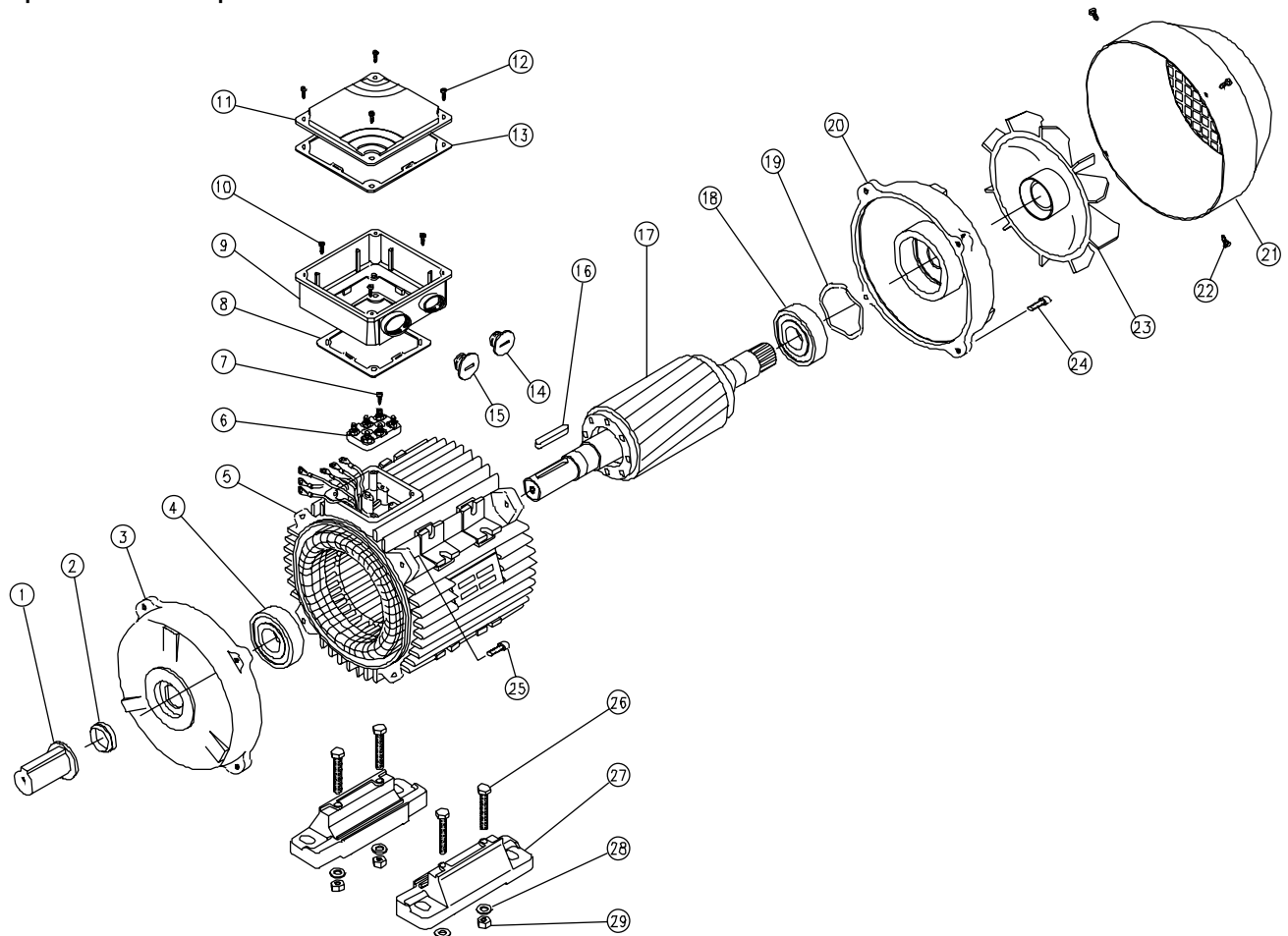

- |    |                               |    |                                     |
|----|-------------------------------|----|-------------------------------------|
| 1  | Shaft protection              | 16 | Key                                 |
| 2  | Dust seal drive end           | 17 | Rotor complete                      |
| 3  | Endshield drive end           | 18 | Bearing non-drive end               |
| 4  | Bearing drive end             | 19 | Pre-load washer                     |
| 5  | Stator frame                  | 20 | Endshield non-drive end             |
| 6  | Terminal board                | 21 | Fan cover                           |
| 7  | Fixing screw terminal board   | 22 | Fixing screw fan cover              |
| 8  | Gasket terminal box           | 23 | Fan                                 |
| 9  | Terminal box                  | 24 | Fixing bolt endshield non-drive end |
| 10 | Fixing screw terminal box     | 25 | Fixing bolt endshield drive end     |
| 11 | Terminal box lid              | 26 | Fixing bolt motor feet              |
| 12 | Fixing screw terminal box lid | 27 | Motor feet                          |
| 13 | Gasket terminal box lid       | 28 | Fixing washer motor feet            |
| 14 | Blank gland plug              | 29 | Fixing nut motor feet               |
| 15 | Blank gland plug              |    |                                     |

In enquires and orders for spare parts please state always:  
 Designation of spare part, motor type, mounting arrangement, motor serial number  
 (Product No. when available)  
 Enquires and orders cannot be handled without these data.  
 Multimounting facility from 71-160 frame (for aluminium motors)



## Bearing details

Classification of bearings (standard design)

Frame size	No. of poles	Drive end	Non-drive end
56	2 & 4	6201-2Z	6201-2Z
63	2 & 4	6201-2Z	6201-2Z
71	2 - 8	6202-2Z	6202-2Z
80	2 - 8	6204-2Z C3	6204-2Z C3
90	2 - 8	6205-2Z C3	6205-2Z C3
100	2 - 8	6206-2Z C3	6206-2Z C3
112	2 - 8	6306-2Z C3	6306-2Z C3
132	2 - 8	6208-2Z C3	6208-2Z C3

Frame size	No. of poles	Drive end	Non-drive end
160	2 - 8	6309-2Z C3	6309-2Z C3
180	2 - 8	6310-2Z C3	6310-2Z C3
200	2 - 8	6312-C3	6312-C3
225	2 - 8	6313-C3	6313-C3
250	2 - 8	6314 C3	6314 C3
280	2	6314 C3	6314 C3
280	4 - 8	6317 C3	6317 C3
315	2	6317 C3	6317 C3
315	4 - 8	6319 C3	6319 C3
355	2	6319 C3	6319 C3
355	4 - 8	6322 C3	6322 C3

## Recommended pulley diameters

Sync. RPM	Frame	63	71	80	90	100	112	132	160	180	200	225	250	280	315	355
3000	Pulley Dia (mm)	75	75	75	75	75	100	120	120	125	130	170	180	300	500	600
1500 and below	Pulley Dia (mm)	75	75	75	75	75	100	120	180	200	220	260	220	220	420	450
	Face width (mm)	30	40	50	63	80	100	125	177	203	280	330	380	380	380	400

## Maximum permissible axial forces without additional radial forces\*

Frame size	3000 RPM kN	Horizontal shaft				Vertical shaft - force upwards				Vertical shaft - force downwards			
		1500 RPM kN	1000 RPM kN	750 RPM kN	3000 RPM kN	1500 RPM kN	1000 RPM kN	750 RPM kN	3000 RPM kN	1500 RPM kN	1000 RPM kN	750 RPM kN	
56	0.16	0.21	-	-	0.18	0.22	-	-	0.15	0.19	-	-	
63	0.19	0.26	-	-	0.21	0.28	-	-	0.17	0.24	-	-	
71	0.23	0.33	0.33	0.37	0.26	0.35	0.36	0.39	0.21	0.30	0.31	0.34	
80	0.32	0.44	0.46	0.50	0.34	0.47	0.48	0.53	0.29	0.41	0.43	0.47	
90	0.34	0.48	0.49	0.54	0.38	0.47	0.53	0.58	0.31	0.44	0.46	0.51	
100	0.48	0.68	0.70	0.77	0.54	0.74	0.76	0.83	0.43	0.62	0.64	0.71	
112	0.48	0.68	0.70	0.77	0.56	0.75	0.77	0.84	0.40	0.60	0.62	0.69	
132	0.6	0.9	1.1	1.3	1.0	1.3	1.5	1.9	0.5	0.75	0.75	1.05	
160	0.5	0.8	1.2	1.5	1	1.4	1.8	2	0.2	0.4	0.6	0.9	
180	0.5	0.8	1.2	1.5	1.1	1.4	1.8	2.1	0.2	0.4	0.6	0.9	
200	0.8	1.3	1.5	1.8	1.8	2.3	2.5	2.8	0.2	0.7	0.9	1.1	
225	1.0	1.6	1.9	2.4	2.1	2.6	2.9	3.4	0.3	0.70	1.0	1.5	
250	1.1	1.6	2.0	2.5	2.3	2.7	3.2	3.7	0.2	0.60	1.1	1.5	
280	1.7	1.9	2.4	2.9	2.9	3.1	3.6	3.7	0.15	0.3	0.8	1.0	
315	3.5	4.0	4.5	5.0	6.0	7.0	7.5	8.0	1.0	1.9	2.4	2.9	

Values for 50 Hz. For service on 60 Hz, reduce values by 10%

\* Consult according to direction of force

**Permissible radial forces**

without additional axial force  
(Ball bearings)

Nominal life = 20.000 h (Lh10)

$F_R$  = permissible radial force in kN

$X$  = Distance between point of application of force  
and shaft shoulder (e.g. half pulley width)

Frame size	$F_R$ in kN			
	2 Pole	4 Pole	6 Pole	8 Pole
56	340	428	-	-
63	385	485	-	-
71	463	583	668	735
80	590	830	860	945
90SL	675	940	975	1070
100L	925	1295	1335	1470
112M	930	1300	1340	1476

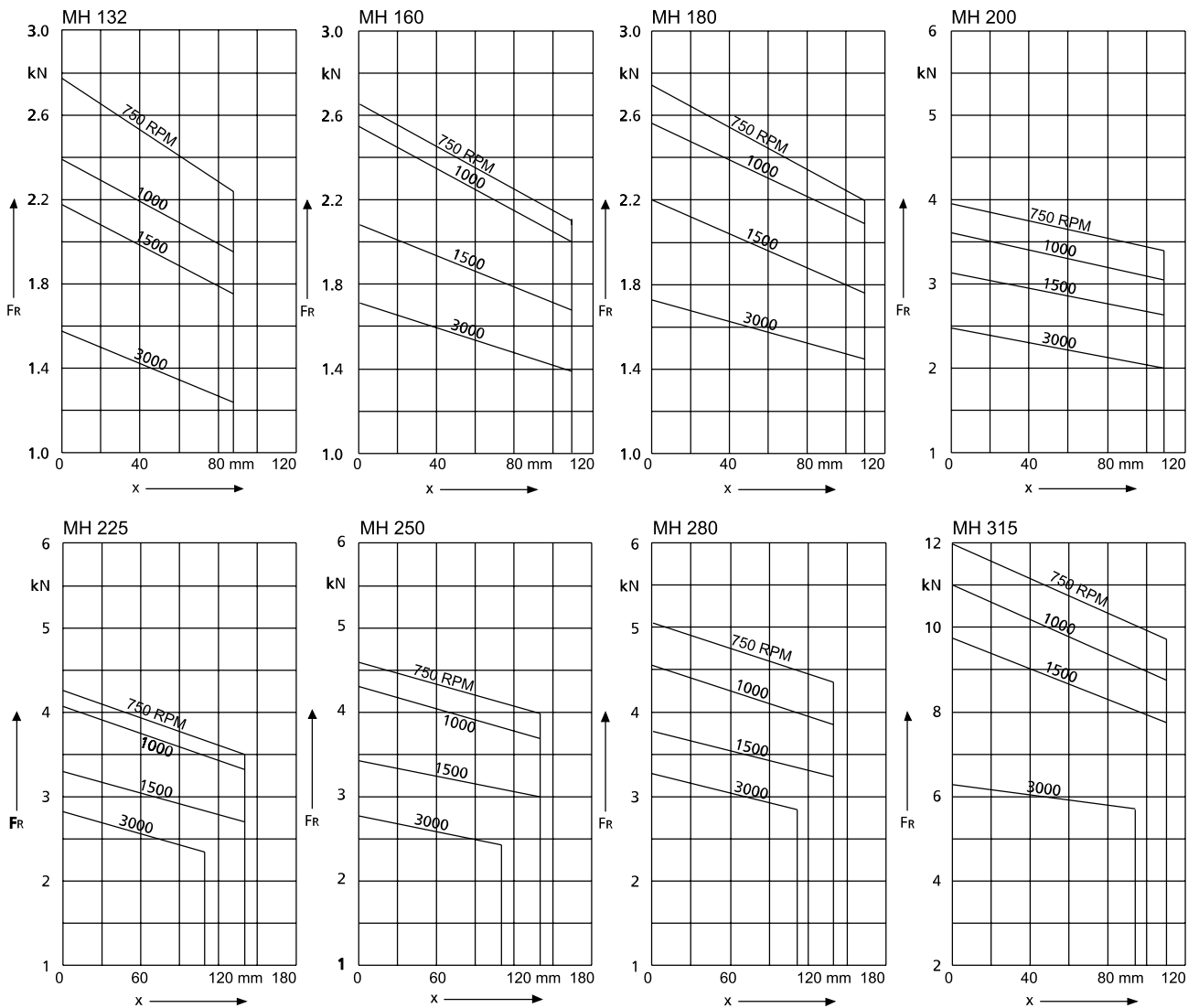



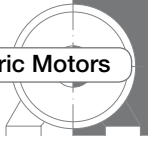

### Lubrication and maintenance of bearings

Maintenance-free life for motors with permanent lubrication upto frame 180 at ambient temperature of 50° C and service at 50 Hz:

2 and 4/2 pole motors 10,000 h

4 and more pole motors 20,000 h, but not more than 4 years.

From frame size 200 upwards the motors are equipped with regreasing device and grease slinger.

For motors with regreasing device, regreasing interval and required quantity of grease is indicated on the nameplate.

For regreasing please observe the Operating Instructions.

Where unfavourable conditions prevail (e.g. high ambient temperature, dusty conditions, corrosive atmosphere, operation by frequency converter), relubrication should be carried out more frequently.

### Permissible operating speed

For motors of standard design, the following maximum operating speeds are permitted:

Frame size	2 Pole RPM	4 - 8 Pole RPM
56-112	3600	1800
132-180	6000	6000
200	5000	5000
225	4500	4500
250	4300	4300
280	3600	2600
315	3600	2300
355	3600	2200

### Belt drive

The data apply only to the normal drive end shaft extension of B3 motors with one speed.

Calculation of belt drive:

$$F_R = \frac{19120 \times P \times k}{D_1 \times n}$$

$F_R$  = Radial shaft load in N

$P$  = Output in kW

$n$  = Speed in min<sup>-1</sup>

$D_1$  = Pulley diameter in m

$k$  = Belt tension factor, varying with the type of belt, assumed to be approximately:

3-4 for normal flat belt without idler pulley

2-2.5 for normal flat belt with idler pulley

2.2-2.5 for V-belt

For exact data apply to the belt manufacturer.

### Noise level

The permitted noise levels of electrical machines are fixed in IS 12065 / IEC 60034 - 9 (IEC 34 - 9). The noise level of our motors is well below these limit values.

The noise values listed below refer to 50 Hz at rated voltage. Values for pole-changing motors on request. For 60 Hz supply values are 3-5 dB(A) higher.

Sound power level  $L_{WA}$  for three-phase single-speed motors are given below

Frame size	2 Pole $L_{WA}$	4 Pole $L_{WA}$	6 Pole $L_{WA}$	8 Pole $L_{WA}$
56	80	76		
63	80	76		
71	80	76	76	
80	80	76	76	72
90	85	78	76	72
100	89	83	75	72
112	89	83	75	75
132	90	87	80	78
160	98	91	84	80
180	98	93	89	81
200	99	93	89	85
225	101	96	92	86
250	101	96	92	88
280	107	104	97	92
315	110	106	104	96
355	112	109	106	100

### Vibration level

The amplitude of vibration in electric motors is governed by IS 12075 / IEC 60034-14 Mechanical vibration of rotating electrical machines with shaft heights 56 and larger - methods of measurement and limits

Standard motors are designed to vibration grade A (normal). Vibration grade B are available at extra cost.

Rotors are at present dynamically balanced with half key fitted as per IS 12075. Other balancing can be offered on request.

The maximum level of vibrations measured as per IS 12075-1987 are: max vibration velocity, mm/s rms are:

Pole	Frame 71-132	Frame 160-225	Above Frame 225
2P	1.8	2.8	4.5
4P-8P	1.8	1.8	2.8

If the machine vibrates even after proper alignment on an amply sized foundation, this could be caused by incorrectly balanced pulley, coupling shaft or similar, fitted to the shaft. Other causes could be weak foundation structure generation vibrations.

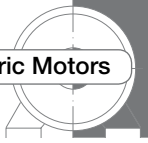

## Terminal box

Terminal box is provided on top as a standard practice. However, terminal box on either side is also available on request.

The terminal boxes are of industrial nylon grade for frame sizes 56 to 71. For frame sizes 80 to 160, the terminal boxes are die cast aluminum alloy and from 180 frame onwards the terminal boxes are of sheet metal / cast iron.

All motors are provided with six terminals as a standard practice. The markings U1 V1 W1 and U2 V2 W2 are provided on the terminal blocks.

## Cable size

Frame	Maximum Cable Size		No. of Terminals	Terminal			Cable Entry Size		
	Main DOL	Stud Size Star/Delta		Main	Earth	Nos.			
56 - 71	4Cx4mm <sup>2</sup>	–	6	M4	M4	2	M16	M20	-
80	4Cx4mm <sup>2</sup>	–	6	M4	M4	2	M20	M25	-
90	4Cx10mm <sup>2</sup>	4Cx10mm <sup>2</sup>	6	M5	M4	2	M20	M25	-
100	4Cx10mm <sup>2</sup>	–	6	M5	M4	2	M20	M25	-
112	4Cx10mm <sup>2</sup>	4Cx10mm <sup>2</sup>	6	M5	M4	2	M20	M25	-
132	4Cx10mm <sup>2</sup>	4Cx10mm <sup>2</sup>	6	M5	M4	2	M32	M32	-
160	3Cx50mm <sup>2</sup>	2x3Cx35mm <sup>2</sup>	6	M6	M4	2	M40	M40	-
180	3Cx50mm <sup>2</sup>	2x3Cx35mm <sup>2</sup>	6	M8	M5	2	M40	M40	M20
200	3Cx50mm <sup>2</sup>	2x3Cx35mm <sup>2</sup>	6	M8	M5	2	M50	M50	M25
225	3Cx120mm <sup>2</sup>	2x3Cx95mm <sup>2</sup>	6	M10	M6	2	M50	M50	M25
250	3Cx120mm <sup>2</sup>	2x3Cx95mm <sup>2</sup>	6	M10	M6	2	M50 / M63	M50 / M63	M25
280	3Cx120mm <sup>2</sup>	2x3Cx95mm <sup>2</sup>	6	M10	M6	2	M63	M63	-
315	3Cx400mm <sup>2</sup>	2x3Cx300mm <sup>2</sup>	6	M16	M8	2	M63	M63	-
355	3Cx400mm <sup>2</sup>	2x3Cx300mm <sup>2</sup>	6	M20	M8	2	M63	M63	-

### Testing of Motors

All motors are tested in accordance with IS 325.

#### Type Tests

The following tests are carried out on one motor in a batch production or on motors specially required to be type tested as per customer's requirement. All tests included in routine tests and following additional tests are carried on the motor.

- a. Measurement of stator resistance
- b. No Load Test
- c. Locked rotor test at reduced voltage and measurement of current, voltage & power input of motors.
- d. Full load reading of voltage, current, power input and slip.
- e. Temperature rise test The temperature rise of the motor after being run on full load till steady state is reached
- f. Resistance method-Momentary overload test
- g. Insulation resistance test
- h. High voltage test

#### Routine Tests

The following are the routine tests carried out on each and every motor.

- a. Measurement of resistance
- b. Insulation resistance test.
- c. Motors are tested at  $1/\sqrt{3}$  times the rated voltage for checking the ability of the motor to run up to the full speed, when switched in either direction.
- d. No load test. This test is carried out at rated voltage and the readings for current, rpm & power input are noted.
- e. Locked rotor test This test is carried at a reduced voltage and the readings for current and power input are noted.
- f. High voltage test

The meters used for noting the above readings have class 0.5 class accuracy.

#### Other Tests

Apart from the above tests mentioned in the Indian Standards, following additional tests can be offered.

- a. Over speed test Running of motor at 1.2 times the maximum rated speed for 2 Mins at no load.
- b. Vibration test Carried out as per IS :12075
- c. Noise level of the motors measured as per IS:12065

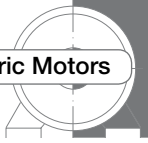

## Order Data

### Motor Code

Apart from other information, it is necessary to specify the exact type designation in all enquiries, when ordering spare parts or replacement motors or when asking for documentary information.

The type designation of our motors comprises 8 points of reference, each of which may consist of several letters and/or numerals. The meaning of each symbol can be seen from the following table. For motors not included in our standard range, special symbols may be used which are not listed here.

### Meaning of the symbols

Ref. point	Meaning	Description of symbols used for our motors	
1	Product	M	Motor
2	Brand	H	Havells
3	Type of motor	blank	Three-phase motor
		H	Three-phase motor, efficiency to EPACT regulations
		HE	Three-phase motor, efficiency EFF 1 to CEMEP Voluntary Agreement
4	Shaft centre height	56, 63, 71, 80, 90, 100, 112, 132, 160, 180, 200, 225, 250, 280, 315, 355	
5	Frame length	Z	Mechanical dimension (short) Mechanical dimension (medium) Mechanical dimension (long)
		S	
		M	
		L	
6	Mechanical design and output value	A	For Internal use
		B	
		...	
		Z	
7	Frame material and/or stage of development	A	Aluminium frame
		G	Cast iron frame
		E	Stage of development
8	Number of poles	2	4/2
		4	8/4
		6	4/6
		8	6/8

### Example

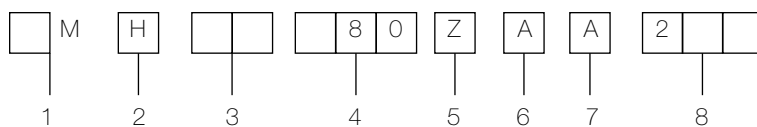

## TECHNICAL DETAILS

Three - phase motors designed  
for range of rated voltage  
415 V ± 10% - 50 Hz ± 5%



Insulation class F with  
temperature rise limited to class B

Type	Rated output		Rated speed RPM	Efficiency			Power factor cos j	Rated current at 415 V $I_N$	Direct-on-line starting			Pull-up torque ratio $M_S/M_N$	Pull-out torque ratio $M_X/M_N$	Moment of inertia $J$ 10 <sup>-3</sup> kgm <sup>2</sup>	Weight	
	kW	HP		50%	75%	100%			starting current ratio $I_s/I_N$	Breakaway torque ratio $M_s/M_N$	kg (AL)				Kg (CI)	
<b>3000 RPM (2 Pole)</b>																
MHHE 80Z BA	2	1.1	1.5	2,880	82.0	83.8	83.8	0.77	2.43	4.8	3.4	3.2	3.4	0.89	9.5	↔
MHHE 90S AA	2	1.5	2.0	2,880	82.8	83.1	84.3	0.80	3.1	6.5	3.3	2.8	3.7	1.56	14	↔
MHHE 90L CA	2	2.2	3.0	2,860	84.9	85.8	86.0	0.85	4.3	5.2	3.2	2.9	3.4	1.8	16	↔
MHHE 100L AA	2	3.0	4.0	2,920	85.1	85.8	86.7	0.84	5.6	5.2	3.6	4.1	5.2	4.05	22.8	↔
MHHE 100L BA	2	3.7	5.0	2,940	86.5	87.6	89.0	0.86	6.7	5.5	3.0	2.0	4.1	8.58	33.6	↔
MHHE 112M BA	2	5.5	7.5	2,920	86.8	87.5	88.6	0.88	9.6	5.5	2.8	2.0	3.0	8.58	34	↔
MHHE 132S ZA	2	5.5	7.5	2,900	88.5	89.2	89.3	0.90	9.5	7.0	2.6	2.1	3.1	14	46	60
MHHE 132S TA	2	7.5	10	2,900	89.4	90.2	90.2	0.90	12.7	7.0	2.8	2.5	3.5	20.5	53	67
MHHE 160M YA	2	11	15	2,930	89.9	91.1	91.3	0.86	19.1	7.0	2.4	2.2	3.1	51.7	87.8	118
MHHE 160M ZA	2	15	20	2,930	91.7	92.0	92.1	0.86	26.0	7.0	2.5	2.3	3.1	64	104	134
MHHE 160L ZA	2	18.5	25	2,930	91.8	92.3	92.5	0.86	31.6	7.0	2.5	2.3	3.2	64	105	135
MHHE 180M ZA	2	22	30	2,930	91.9	92.8	92.8	0.88	37.2	7.0	2.5	2.3	2.7	70	↔	135
MHHE 200L PG	2	30	40	2,945	92.4	93.1	93.3	0.89	50.0	7.0	2.3	2.1	2.5	130	↔	220
MHHE 200L RG	2	37	50	2,950	92.6	93.5	93.7	0.89	61.0	7.0	2.3	2.1	2.5	156	↔	240
MHHE 225M P	2	45	60	2,955	93.0	94.0	94.1	0.89	73.5	7.0	2.3	1.9	2.9	270	↔	315
MHHE 250M P	2	55	75	2,960	93.6	94.2	94.4	0.89	88.9	7.0	2.3	1.9	3.0	424	↔	410
MHHE 280S V	2	75	100	2,970	93.2	94.7	94.4	0.90	122.0	7.2	1.7	1.5	2.5	579	↔	525
MHHE 280M V	2	90	125	2,970	93.5	95.0	95.2	0.91	145.0	7.2	1.7	1.5	2.5	675	↔	570
MHHE 315S YE	2	110	150	2,980	93.5	95.0	95.4	0.91	177.0	7.2	1.6	1.5	2.2	1,180	↔	930
MHHE 315M ZE	2	132	180	2,980	93.8	95.3	95.5	0.91	211.0	7.2	1.6	1.5	2.2	1,820	↔	990
MHHE 315L YE	2	160	220	2,980	94.1	95.6	95.6	0.92	253.0	7.2	1.6	1.5	2.2	2,080	↔	1,090
MHHE 315L ZE	2	200	270	2,980	94.3	95.8	95.9	0.92	317.0	7.2	1.6	1.5	2.2	2,380	↔	1,120
MHHE 355M B	2	250	340	2,980	94.5	96.0	96.0	0.92	394.0	7.2	1.6	1.5	2.2	3,000	↔	1,900
MHHE 355L B	2	315	430	2,980	95.0	96.0	96.0	0.92	496.0	7.2	1.6	1.5	2.2	3,500	↔	2,300

Note: Performance figures are subject to IS tolerance  
80 to 160 frames are also available in Cast Iron body

As per IS: 12615

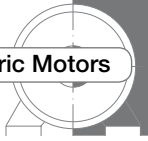

Three - phase motors designed  
for range of rated voltage  
415 V  $\pm$  10% - 50 Hz  $\pm$  5%

EFF I

Type	Rated output		Rated speed RPM	Efficiency			Power factor cos $\phi$	Rated current at 415 V $I_N$	Direct-on-line starting			Pull-up torque ratio $M_S/M_N$	Pull-out torque ratio $M_X/M_N$	Moment of inertia $J$ $10^{-3}$ kgm <sup>2</sup>	Weight	
	kW	HP		50%	75%	100%			starting current ratio $I_s/I_N$	Breakaway torque ratio $M_s/M_N$	kg (AL)				CI (Kg)	
<b>1500 RPM (4 Pole)</b>																
MHHE 90S AA	4	1.1	1.5	1,430	83.1	84.1	84.2	0.77	2.4	6.1	3.6	3.4	3.8	3.73	16.4	16.4
MHHE 90L BA	4	1.5	2.0	1,430	85.0	85.4	85.4	0.77	3.1	6.4	3.6	3.4	3.8	3.73	16.4	-
MHHE 100L AA	4	2.2	3.0	1,450	85.2	86.2	86.5	0.76	5.1	6.0	2.8	2.6	3.0	5.58	22.4	-
MHHE 100L BA	4	3.0	4.0	1,440	86.2	87.2	87.2	0.77	6.2	6.0	2.8	2.6	3.0	7.3	26.5	-
MHHE 112M AA	4	3.7	5.0	1,450	87.5	88.5	88.5	0.78	7.1	6.1	2.8	2.6	3.0	13.3	30.4	-
MHHE 132S RA	4	5.5	7.5	1,450	87.9	89.2	89.8	0.79	10.4	6.5	2.6	2.4	3.0	30.0	55.0	69.0
MHHE 132M TA	4	7.5	10	1,450	89.1	90.5	90.5	0.84	13.7	6.5	2.6	2.4	3.0	36.0	65.0	79.0
MHHE 160M ZA	4	11	15	1,460	90.2	91.4	91.4	0.82	20.0	6.5	2.0	1.9	2.7	105.0	105	135
MHHE 160L ZA	4	15	20	1,460	90.9	90.1	92.3	0.84	27.0	6.5	2.1	1.9	2.8	120.7	114	144
MHHE 180M ZA	4	18.5	25	1,460	91.3	92.3	92.6	0.82	33.0	6.5	2.4	2.2	2.5	112.0	-	130
MHHE 180L ZA	4	22	30	1,465	91.8	92.8	93.1	0.84	39.0	6.5	2.2	2.1	3.0	132.0	-	140
MHHE 200L RG	4	30	40	1,465	92.5	93.4	93.7	0.85	51.0	6.5	2.1	1.9	2.6	206.0	-	230
MHHE 225S P	4	37	50	1,475	92.8	93.7	93.9	0.85	64.0	6.5	2.2	2.0	2.7	356.0	-	290
MHHE 225M P	4	45	60	1,475	93.1	93.9	94.3	0.86	77.0	6.5	2.0	1.9	2.8	461.0	-	330
MHHE 250M P	4	55	75	1,475	93.7	94.6	94.8	0.85	94.8	6.5	2.5	2.3	2.7	677.0	-	400
MHHE 280S V	4	75	100	1,485	92.9	94.9	95.1	0.87	126	7.0	1.8	1.6	2.3	1,120	-	515
MHHE 280M V	4	90	125	1,480	94.2	95.0	95.3	0.87	151	7.0	1.8	1.6	2.3	1,460	-	611
MHHE 315S YE	4	110	150	1,480	94.4	95.3	95.6	0.88	182	7.0	1.7	1.5	2.2	3,110	-	931
MHHE 315M YE	4	132	180	1,480	94.5	95.6	95.6	0.88	218	7.0	1.7	1.5	2.2	3,620	-	1,017
MHHE 315L YE	4	160	220	1,480	94.5	95.8	95.8	0.89	261	7.0	1.7	1.5	2.2	4,130	-	1,085
MHHE 315L ZE	4	200	270	1,480	95.0	96.0	96.0	0.89	327	7.0	1.7	1.5	2.2	4,730	-	1,200
MHHE 355M B	4	250	340	1,490	95.0	96.0	96.0	0.90	403	7.0	1.7	1.5	2.2	6,500	-	1,700
MHHE 355L A	4	315	430	1,490	95.0	96.0	96.0	0.90	507	7.0	1.7	1.5	2.2	8,200	-	1,900

Note: Performance figures are subject to IS tolerance  
80 to 160 frames are also available in Cast Iron body

As per IS: 12615



Three - phase motors designed  
for range of rated voltage  
415 V ± 10% - 50 Hz ± 5%

Type	Rated output		Rated speed RPM	Efficiency			Power factor cos j	Rated current at 415 V $I_N$	Direct-on-line starting			Moment of inertia $J$ 10 <sup>-3</sup> kgm <sup>2</sup>	Weight			
	kW	HP		50%	75%	100%			starting current ratio $I_s/I_N$	Breakaway torque ratio $M_s/M_N$	Pull-up torque ratio $M_p/M_N$		Pull-out torque ratio $M_o/M_N$	kg (AL)	Kg (CI)	
<b>1000 RPM (6 Pole)</b>																
MHHE 90S AA	6	0.75	1.0	910	77.9	78.9	79.1	0.72	2.3	4.0	1.7	1.5	1.7	3.18	11.6	↔
MHHE 90L BA	6	1.1	1.5	908	79.3	81.1	81.1	0.72	3.2	5.0	1.7	1.5	1.7	4.78	15.0	↔
MHHE 100LAA	6	1.5	2.0	930	77.4	82.4	82.6	0.71	3.8	5.0	3.6	3.1	4.0	6.73	17.5	↔
MHHE 112MAA	6	2.2	3.0	940	83.6	84.1	84.3	0.76	5.0	5.0	2.2	2.1	2.5	14.18	26.0	↔
MHHE 132S YA	6	3.7	5.0	950	85.1	86.4	86.6	0.76	8.1	5.0	2.2	2.0	2.4	29.5	42.5	↔
MHHE 132M ZA	6	5.5	7.5	950	86.6	88.0	88.2	0.76	11.5	5.5	2.2	1.9	2.3	37.3	55.0	69
MHHE 160MZA	6	7.5	10	970	88.1	89.0	89.2	0.76	15.6	6.0	1.9	1.8	2.0	81.2	99.0	129
MHHE 160LZA	6	11	15	960	89.9	90.4	90.4	0.84	21.0	6.0	2.4	2.2	3.2	105.7	113.6	143
MHHE 180L ZG	6	15	20	970	90.8	91.1	91.3	0.84	29.0	6.7	2.2	1.8	2.8	169	↔	155
MHHE 200L PG	6	18.5	25	970	91.1	91.9	91.1	0.84	33.6	6.5	2.2	1.8	2.3	260	↔	210
MHHE 200L RG	6	22	30	975	91.3	92.3	92.4	0.84	39.5	6.5	2.2	1.8	2.3	285	↔	220
MHHE 225M P	6	30	40	975	92.0	92.8	92.9	0.84	53.0	6.5	2.3	1.6	2.3	536	↔	290
MHHE 250M P	6	37	50	975	92.0	93.0	93.4	0.84	65.5	6.5	2.7	2.5	2.6	880	↔	380
MHHE 280S V	6	45	60	980	91.6	93.6	93.7	0.86	77.7	7.0	1.8	1.6	2.0	1,390	↔	498
MHHE 280M V	6	55	75	980	92.0	94.0	94.2	0.86	94.7	7.0	1.8	1.6	2.0	1,650	↔	545
MHHE 315S YE	6	75	100	985	92.4	94.4	94.6	0.86	128	7.0	1.8	1.6	2.0	4,110	↔	915
MHHE 315M YE	6	90	125	985	92.7	94.7	94.9	0.86	153	7.0	1.8	1.6	2.0	4,780	↔	993
MHHE 315M ZE	6	110	150	985	92.8	94.8	95.1	0.86	187	7.0	1.8	1.6	2.0	5,450	↔	1,065
MHHE 315L ZE	6	132	180	985	93.2	95.2	95.4	0.87	221	7.0	1.8	1.6	2.0	6,120	↔	1,185
MHHE 355M A	6	160	220	990	93.4	95.4	95.6	0.87	264	7.0	1.8	1.6	2.0	9,500	↔	1,550
MHHE 355M C	6	200	270	990	93.6	95.6	95.4	0.88	332	7.0	1.8	1.6	2.0	10,400	↔	1,600
MHHE 355L A	6	250	340	990	93.6	95.6	95.9	0.88	416	7.0	1.8	1.6	2.0	12,400	↔	1,700

Note: Performance figures are subject to IS tolerance  
80 to 160 frames are also available in Cast Iron body

As per IS: 12615



EFF 2

Three - phase motors designed  
for range of rated voltage  
415 V  $\pm$  10% - 50 Hz  $\pm$  5%

Insulation class F with  
temperature rise limited to class B

Type	Rated output		Rated speed RPM	Efficiency			Power factor cos $\phi$	Rated current at 415 V $I_N$	Direct-on-line starting			Moment of inertia $J$ 10 <sup>-3</sup> kgm <sup>2</sup>	Weight AL/CI (kg)		
	kW	HP		50%	75%	100%			starting current ratio $I_s/I_N$	Breakaway torque ratio $M_x/M_N$	Pull-up torque ratio $M_s/M_N$			Pull-out torque ratio $M_x/M_N$	
<b>3000 RPM (2 Pole)</b>													<b>Aluminium Frame</b>		
MH 56Z AA	2	0.09	0.12	2,810	52.1	56.1	61.4	0.66	0.38	3.9	3.8	3.8	3.9	0.09	3.4
MH 56Z BA	2	0.12	0.16	2,800	53.9	58.9	64.5	0.70	0.40	3.9	3.8	3.8	3.9	0.1	3.5
MH 63Z AA	2	0.18	0.25	2,790	56.8	60.8	65.8	0.79	0.52	4.2	3.0	3.1	3.2	0.13	4.1
MH 63Z BA	2	0.25	0.33	2,790	61.6	66.4	70.5	0.72	0.71	4.5	3.2	3.2	3.3	0.19	4.6
MH 63Z CA	2*	0.37(1)	0.50(1)	2,800	59.6	63.6	68.6	0.75	1.1	4.6	3.4	3.3	3.4	0.2	4.7
MH 71Z AA	2	0.37	0.5	2,820	60.2	66.7	62.2	0.75	1.1	4.7	3.6	3.4	3.6	0.36	5.7
MH 71Z BA	2	0.55	0.75	2,830	61.4	68.4	75.2	0.75	1.61	4.8	3.2	3.1	3.3	0.46	6.3
MH 71Z CA	2*	0.75(1)	1.0(1)	2,800	62.4	68.7	75.4	0.79	1.9	5.2	3.1	3.2	3.1	0.58	6.9
MH 80Z AA	2	0.75	1.0	2,840	71.2	76.5	78.0	0.82	1.9	5.0	2.8	2.8	2.9	0.75	8.4
MH 80Z BA	2	1.1	1.5	2,810	76.4	79.4	79.7	0.85	2.47	4.6	2.4	2.8	2.9	0.89	9.5
MH 80Z CA	2*	1.5(1)	2.0(1)	2,825	78.1	80.6	80.7	0.86	3.1	5.0	2.9	3.0	3.3	1.05	11.1
MH 90S AA	2	1.5	2.0	2,830	80.0	81.1	81.3	0.85	3.2	5.0	3.1	2.9	3.0	1.37	12.7
MH 90S BA	2*	1.8	2.5	2,805	76.7	79.9	80.1	0.83	3.4	4.5	2.6	2.4	2.5	1.37	12.7
MH 90L CA	2	2.2	3.0	2,860	81.1	82.9	89.3	0.84	4.62	6.8	4.1	3.6	4.0	1.8	16
MH 90L DA	2*	3(1)	4.0(1)	2,860	80.1	83.2	83.6	0.83	6.11	6.8	3.9	3.4	3.8	2.09	18.7
MH 100L AA	2	3.0	4.0	2,860	83.0	83.7	83.9	0.88	6.21	6.0	3.1	3.1	3.3	2.8	19.3
MH 100L BA	2*	3.7	5.0	2,835	84.6	85.2	85.7	0.90	7.11	6.2	2.9	2.5	2.9	3.35	19.7
MH 100L CA	2*	5.5(1)	7.5(1)	2,865	84.6	86.0	86.1	0.88	10.1	6.5	2.7	3.4	4.1	4.5	25.9
MH 112M AA	2	3.7	5.0	2,880	82.0	85.3	86.9	0.87	7.46	6.5	2.8	3.6	3.6	5.2	24.3
MH 112M BA	2*	5.5	7.5	2,900	85.9	86.5	86.5	0.88	10.05	6.5	2.8	3.4	3.6	6.48	27.4
MH 132S YA	2	5.5	7.5	2,890	85.0	87.0	87.0	0.88	10.11	6.0	2.2	2.1	2.3	10	37 / 51
MH 132S ZA	2	7.5	10	2,880	87.6	88.1	88.1	0.91	13.18	6.4	2.9	2.7	3.0	14	42.5 / 56.5
MH 132M ZA	2*	9.3(1)	12.5(1)	2,890	85.3	87.4	88.0	0.86	17.1	6.5	2.6	2.8	3.5	17.1	51.4 / 65
MH 132M RA	2*	11	15	2,880	88.5	89.0	89.0	0.89	19.32	6.5	2.6	2.8	3.8	17.1	53 / 67
MH 132M TA	2*	15(1)	20(1)	2,920	87.3	88.3	88.8	0.90	26.11	6.5	2.6	2.8	3.7	20.3	59 / 73
MH 160M TG	2	9.3	12.5	2,930	89.2	89.7	90.0	0.87	17.0	6.5	2.0	2.2	3.0	40	77 / 107
MH 160M VA	2	11	15	2,940	87.4	89.3	89.5	0.87	19.74	6.5	2.0	2.2	3.0	40	77 / 107
MH 160M XA	2	15	20	2,940	88.8	90.4	90.5	0.88	26.2	6.5	2.6	2.6	3.7	51.7	93 / 123
MH 160L XA	2	18.5	25	2,950	89.5	91.0	91.1	0.88	32.11	6.5	2.8	3.0	4.2	64	107.8 / 138
MH 160L RA	2*	22(1)	30(1)	2,940	89.7	91.5	91.5	0.89	37.59	6.5	2.5	2.5	3.7	64	108.7 / 139
<b>3000 RPM (2 Pole)</b>													<b>Cast Iron Frame</b>		
MH 180M XG	2	22.0	30	2,925	89.8	91.4	91.5	0.88	38.0	6.5	2.0	2.3	3.2	65	155
MH 180M RG	2*	30(1)	40(1)	2,925	89.9	92.0	92.1	0.88	51.5	6.5	2.3	2.5	3.4	88	175
MH 200L LG	2	30	40	2,945	89.8	91.7	92.2	0.88	51.4	6.5	2.0	2.0	3.0	120	212
MH 200L NG	2	37	50	2,950	90.6	92.4	92.8	0.88	63.0	6.5	2.0	2.0	3.0	145	230
MH 225M N	2	45	60	2,960	91.5	93.0	93.2	0.91	73.8	6.5	2.0	1.9	2.8	270	310
MH 250M N	2	55	75	2,960	91.2	93.0	93.4	0.91	90.0	6.5	2.0	1.8	3.0	424	410

1) Temperature rise to class F

\* Higher output (progressive motor)

Note : Performance figures are subject to IS tolerance, 80 to 160 Frames are also available in Cast Iron body

As per IS: 12615



Three - phase motors designed  
for range of rated voltage  
415 V ± 10% - 50 Hz ± 5%

Insulation class F with  
temperature rise limited to class B

Type	Rated output		Rated speed RPM	Efficiency			Power factor cos φ	Rated current at 415 V I <sub>N</sub>	Direct-on-line starting			Moment of inertia J 10 <sup>-3</sup> kgm <sup>2</sup>	Weight AL/CI (kg)		
	kW	HP		50%	75%	100%			starting current ratio I <sub>s</sub> /I <sub>N</sub>	Breakaway torque ratio M <sub>b</sub> /M <sub>N</sub>	Pull-up torque ratio M <sub>u</sub> /M <sub>N</sub>			Pull-out torque ratio M <sub>p</sub> /M <sub>N</sub>	
<b>1500 RPM (4 Pole)</b>														<b>Aluminium Frame</b>	
MH 56Z AA	4	0.06	0.08	1,300	45.9	47.9	51.9	0.58	0.38	2.6	2.1	2.0	2.1	0.14	3.2
MH 56Z BA	4*	0.09	0.12	1,330	46.7	50.7	54.7	0.66	0.43	2.5	2.2	2.1	2.2	0.14	3.3
MH 63Z AA	4	0.12	0.16	1,350	49.5	53.5	57.5	0.63	0.47	2.4	2.0	1.9	2.0	0.25	4.1
MH 63Z BA	4	0.18	0.25	1,330	55.2	58.2	64.2	0.70	0.62	2.3	1.9	1.8	1.9	0.27	4.6
MH 63Z CA	4*	0.25	0.33	1,360	55.3	58.8	64.3	0.76	0.90	2.7	2.2	2.0	2.1	0.3	4.9
MH 71Z AA	4	0.25	0.33	1,340	57.7	61.7	66.7	0.65	0.80	3.2	1.9	1.8	2.0	0.63	5.2
MH 71Z BA	4	0.37	0.5	1,370	65.0	68.0	72.0	0.71	1.1	3.3	2.2	2.1	2.2	0.76	5.4
MH 71Z CA	4*	0.55	0.75	1,380	65.8	68.8	72.8	0.75	1.64	3.6	2.4	2.3	2.4	0.98	6.3
MH 80Z AA	4	0.55	0.75	1,400	72.2	74.2	75.2	0.78	1.62	3.6	2.6	2.5	2.6	1.58	8.2
MH 80Z BA	4	0.75	1.0	1,410	69.6	76.1	79.7	0.73	2.1	4.4	2.8	2.3	2.8	2.0	9.3
MH 80Z CA	4*	1.1	1.5	1,385	75.9	77.7	77.7	0.81	2.7	4.4	2.5	2.5	2.6	2.41	10.6
MH 90S AA	4	1.1	1.5	1,400	74.6	80.4	81.5	0.82	2.7	5.2	2.5	2.4	2.8	2.5	12.5
MH 90L BA	4	1.5	2.0	1,400	79.9	82.7	82.9	0.81	3.5	5.7	2.8	2.6	3.0	3.13	14.5
MH 90L CA	4*	1.8	2.5	1,380	78.5	80.5	80.7	0.83	4.01	5.5	2.7	2.5	2.9	3.13	14.5
MH 90L DA	4*	2.2	3.0	1,400	79.4	82.4	82.4	0.82	5.21	4.8	2.9	2.8	3.2	4.05	17
MH 100L AA	4	2.2	3.0	1,435	80.9	83.6	84.4	0.78	4.98	5.3	2.5	2.4	2.7	4.6	19.5
MH 100L BA	4	3.0	4.0	1,425	83.0	84.0	84.1	0.80	6.39	4.6	2.4	2.3	2.5	5.58	22.5
MH 100L CA	4*	3.7	5.0	1,400	82.7	83.0	83.0	0.82	8.12	6.0	2.6	2.4	2.9	6.05	25
MH 112M AA	4	3.7	5.0	1,430	86.0	86.5	86.5	0.84	8.00	6.0	2.0	2.0	2.8	12.2	29.5
MH 112M BA	4*	5.5	7.5	1,430	85.2	85.9	86.3	0.86	10.31	6.0	2.0	2.0	2.9	15.2	34
MH 132S ZA	4	5.5	7.5	1,430	86.5	87.5	87.8	0.86	10.25	5.8	3.0	2.7	2.9	22	41.9 / 56
MH 132M ZA	4	7.5	10	1,440	87.6	88.4	88.8	0.88	13.47	6.0	2.6	2.7	2.9	30	51 / 65
MH 132M RA	4*	9.3	12	1,440	87.0	88.0	88.2	0.88	16.67	6.0	2.75	3.0	3.5	37.2	65 / 79
MH 132M TA	4*	11	15	1,440	88.4	88.8	89.4	0.88	19.45	6.0	3.0	3.3	3.5	37.2	65 / 79
MH 160M YA	4	9.3	12	1,460	89.0	89.7	89.9	0.83	17.3	6.0	2.1	2.2	2.9	81.2	88.5 / 118.5
MH 160M XA	4	11	15	1,460	89.3	89.6	89.9	0.83	20.6	6.0	2.1	2.2	2.9	81.2	88.5 / 118.5
MH 160L XA	4	15	20	1,460	90.2	90.7	90.7	0.88	26.23	6.0	2.1	2.2	3.5	105.7	106.5 / 136.5
<b>1500 RPM (4 Pole)</b>														<b>Cast Iron Frame</b>	
MH 180M XG	4	18.5	25	1,460	91.0	92.0	92.0	0.87	32.2	6.0	2.2	2.2	3.0	105	150
MH 180L XG	4	22	30	1,460	91.9	92.0	92.0	0.87	38.2	6.0	2.2	2.2	3.0	118	160
MH 180L RG	4*	30(1)	40(1)	1,455	91.7	92.7	92.7	0.85	52.9	6.0	2.5	2.4	3.2	150	175
MH 200L NG	4	30	40	1,465	91.8	92.8	92.8	0.87	51.7	6.0	2.0	1.8	2.6	195	225
MH 200L FG	4*	37(1)	50(1)	1,465	92.5	93.2	93.2	0.86	64.2	6.0	2.2	2.0	2.8	248	255
MH 225S N	4	37	50	1,475	91.4	92.7	92.8	0.87	63.8	5.9	2.75	2.1	2.9	356	290
MH 225M N	4	45	60	1,475	92.3	93.3	93.2	0.88	76.3	6.0	2.0	2.0	2.9	461	330
MH 250M N	4	55	75	1,475	93.3	93.8	93.8	0.87	93.8	6.0	2.0	2.1	2.4	640	385
MH 250M K	4*	75	100	1,470	92.6	93.7	93.9	0.85	130.7	6.0	3.0	2.3	2.7	812	440

1) Temperature rise to class F

\* Higher output (progressive motor)

Note : Performance figures are subject to IS tolerance. 80 to 160 Frames are also available in Cast Iron body

As per IS: 12615

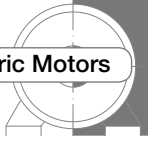

Three - phase motors designed  
for range of rated voltage  
415 V  $\pm$  10% - 50 Hz  $\pm$  5%

Insulation class F with  
temperature rise limited to class B

Type	Rated output		Rated speed RPM	Efficiency			Power factor cos $\phi$	Rated current at 415 V $I_N$	Direct-on-line starting			Moment of inertia $J$ 10 <sup>-3</sup> kgm <sup>2</sup>	Weight AL/CI (kg)		
	kW	HP		50%	75%	100%			starting current ratio $I_s/I_N$	Breakaway torque ratio $M_b/M_N$	Pull-up torque ratio $M_u/M_N$			Pull-out torque ratio $M_o/M_N$	
<b>1000 RPM (6 Pole)</b>														<b>Aluminium Frame</b>	
MH 71Z AA	6	0.18	0.25	850	53.0	56.0	52.0	0.72	0.71	2.2	1.6	1.5	1.6	0.6	5.7
MH 71Z BA	6	0.25	0.33	870	54.0	58.0	60.0	0.70	1.0	2.5	1.7	1.6	1.7	0.9	6.3
MH 80Z AA	6	0.37	0.5	910	69.2	69.2	69.2	0.73	1.18	2.7	1.6	1.6	2.1	1.97	8.0
MH 80Z BA	6	0.55	0.75	910	65.6	64.6	72.9	0.72	1.7	2.9	2.2	2.1	2.1	2.47	9.4
MH 90S AA	6	0.75	1.0	910	73.8	75.6	75.9	0.72	2.31	2.9	1.7	1.5	1.7	3.18	11.6
MH 90L BA	6	1.1	1.5	908	75.8	77.9	78.2	0.72	3.24	3.0	1.7	1.5	1.7	4.78	15
MH 100L AA	6	1.5	2.0	930	76.4	79.6	79.8	0.73	4.05	3.7	1.8	1.8	2.3	6.73	17.5
MH 100L BA	6*	1.8	2.5	940	73.0	77.0	78.0	0.70	5.0	4.2	2.4	2.4	2.8	9.43	22
MH 112M AA	6	2.2	3.0	940	83.4	84.2	84.5	0.76	5.13	4.4	2.4	2.4	2.6	14.18	26
MH 112M BA	6*	3.0	4.0	940	84.2	85.2	85.2	0.77	6.83	5.3	2.9	2.9	2.9	18.7	39
MH 132S ZA	6	3.0	4.0	950	82.8	84.0	84.6	0.73	7.12	4.9	2.1	1.8	2.4	23.5	36.7 / 50.7
MH 132S YA	6	3.7	5.0	950	83.6	84.2	84.8	0.76	8.8	4.5	2.3	2.0	2.5	29.5	42.5 / 56.5
MH 132M ZA	6	5.5	7.5	950	85.7	85.8	86.1	0.76	11.73	4.1	2.3	1.9	2.2	37.3	55.5 / 69.5
MH 132M TA	6*	7.5	10	950	85.3	85.7	86.1	0.76	15.95	5.0	2.3	1.9	2.8	54.1	64.1 / 78.1
MH 160M ZA	6	7.5	10	970	87.8	88.0	88.0	0.76	15.6	6.1	1.9	1.8	1.6	81.2	99 / 129
MH 160M ZB	6	9.3	12.5	968	87.6	87.9	88.3	0.84	17.3	6.0	2.5	2.2	3.5	105.7	113.6 / 143.6
MH 160L ZA	6	11	15	960	88.7	89.0	89.0	0.84	20.47	6.0	2.5	2.2	3.5	105.7	113.6 / 143.6
<b>1000 RPM (6 Pole)</b>														<b>Cast Iron Frame</b>	
MH 180L ZG	6	15	20	970	89.2	89.4	90.2	0.84	27.4	6.7	2.2	1.8	2.8	169	155
MH 200L PG	6	18.5	25	970	91.7	91.9	90.6	0.84	33.4	5.3	2.2	1.8	2.3	260	210
MH 200L RG	6	22	30	975	90.2	90.9	91.1	0.84	39.5	5.7	2.2	1.8	2.3	285	220
MH 225M P	6	30	40	975	90.7	91.2	91.7	0.84	53.5	5.7	2.3	1.6	2.3	536	290
MH 250M P	6	37	50	975	91.3	92.0	92.3	0.85	65.1	6.0	2.8	2.5	2.6	880	380

<sup>1)</sup> Temperature rise to class F

\* Higher output (progressive motor)

Note : Performance figures are subject to IS tolerance. 80 to 160 Frames are also available in Cast Iron body

As per IS: 12615



Three - phase motors designed  
for range of rated voltage  
415 V ± 10% - 50 Hz ± 5%

Insulation class F with  
temperature rise limited to class B

Type	Rated output		Rated speed RPM	Efficiency			Power factor cos φ	Rated current at 415 V $I_N$	Direct-on-line starting			Moment of inertia $J$ 10 <sup>-3</sup> kgm <sup>2</sup>	Weight AL/CI (kg)		
	kW	HP		50%	75%	100%			starting current ratio $I_s/I_N$	Breakaway torque ratio $M_A/M_N$	Pull-up torque ratio $M_U/M_N$			Pull-out torque ratio $M_K/M_N$	
<b>750 RPM (8 Pole)</b>													<b>Aluminium Frame</b>		
MH 71Z AA	8	0.12	0.16	670	47.7	51.7	52.0	0.55	0.71	2.4	2.5	2.4	2.5	0.9	6.3
MH 80Z AA	8	0.25	0.33	680	51.4	54.4	55.0	0.65	1.1	2.2	1.8	1.9	2.0	1.97	8.0
MH 90S AA	8	0.37	0.5	680	58.2	61.6	62.1	0.57	1.71	2.1	1.4	1.3	1.6	3.18	11.4
MH 90L BA	8	0.55	0.75	680	58.2	61.8	62.1	0.58	2.54	2.1	1.4	1.3	1.6	4.78	15.0
MH 100L AA	8	0.75	1.0	690	64.3	69.3	70.3	0.68	2.63	3.0	1.6	1.5	1.7	6.72	17.6
MH 100L BA	8	1.1	1.5	690	63.8	71.8	72.0	0.68	3.72	3.0	1.9	1.3	1.4	15.93	22.6
MH 112M AA	8	1.5	2.0	696	70.5	73.5	74.5	0.69	4.54	4.0	1.8	2.0	2.4	16.7	35
MH 132S ZA	8	2.2	3.0	710	82.2	82.6	83.7	0.69	5.4	3.4	1.7	1.6	1.7	29.5	45.5 / 59.5
MH 132M ZA	8	3.0	4.0	710	84.3	84.9	85.2	0.73	6.86	3.6	1.7	1.6	2.1	37.7	54.4 / 68.5
MH 132M ZB	8	3.7	5.0	715	83.7	84.1	84.7	0.77	10.3	4.0	1.8	1.6	2.3	119.5	90.5 / 90.5
MH 160M ZA	8	5.5	7.5	720	86.3	86.7	86.7	0.77	11.52	4.0	1.8	1.6	2.3	119.5	90.5 / 120.5
MH 160L ZA	8	7.5	10.0	710	87.4	86.1	86.9	0.78	15.39	4.0	1.8	1.6	2.3	150.2	98 / 128
<b>750 RPM (8 Pole)</b>													<b>Cast Iron Frame</b>		
MH 180L YG	8	9.3	12.5	725	84.8	85.7	86.0	0.78	21.5	4.6	2.1	1.4	1.9	215	175
MH 180L ZG	8	11	15.0	725	87.7	87.9	88.8	0.78	22.3	4.6	2.1	1.4	1.9	215	175
MH 200L RG	8	15	20.0	730	88.1	89.4	89.7	0.78	29.9	5.3	2.3	1.9	2.5	285	220
MH 225S P	8	18.5	25.0	730	89.4	90.3	90.6	0.79	36.1	5.2	2.3	1.9	2.2	438	255
MH 225M P	8	22	30.0	730	89.5	90.3	90.7	0.79	42.9	5.6	2.5	2.0	2.3	538	285
MH 250M P	8	30	40.0	730	89.4	90.9	90.9	0.80	57.4	6.0	2.8	2.5	2.6	1,080	400
MH 280S V	8	37	50.0	735	89.5	91.5	91.5	0.79	71.5	6.0	1.9	1.7	2.0	1,930	472
MH 280M V	8	45	60.0	735	90.4	91.9	92.1	0.79	86	6.0	1.8	1.65	2.0	3,650	538
MH 315S YE	8	55	75.0	735	91.3	92.8	93.0	0.81	102	6.0	1.8	1.65	2.0	4,790	900
MH 315M YE	8	75	100	735	91.5	93.0	93.2	0.81	138	6.0	1.8	1.65	2.0	5,580	1,000
MH 315M ZE	8	90	125	735	92.3	93.8	94.0	0.82	162	6.0	1.8	1.65	2.0	6,370	1,055
MH 315L ZE	8	110	150	735	92.5	94.0	94.1	0.82	199	6.0	1.8	1.65	2.0	7,230	1,118
MH 355M A	8	132	180	740	92.5	93.7	94.0	0.82	239	6.0	1.8	1.65	2.0	7,900	2,000
MH 355M C	8	160	220	740	92.5	93.9	94.2	0.82	288	6.0	1.8	1.65	2.0	10,300	2,150
MH 355L B	8	200	270	740	92.6	94.3	94.5	0.82	360	6.0	1.8	1.65	2.0	12,300	2,250

<sup>1)</sup> Temperature rise to class F

Note : Performance figures are subject to IS tolerance

80 to 160 Frames are also available in Cast Iron body

As per IS: 12615

GA DRAWING

Frame Size 56-355  
Foot Mounted (B3)

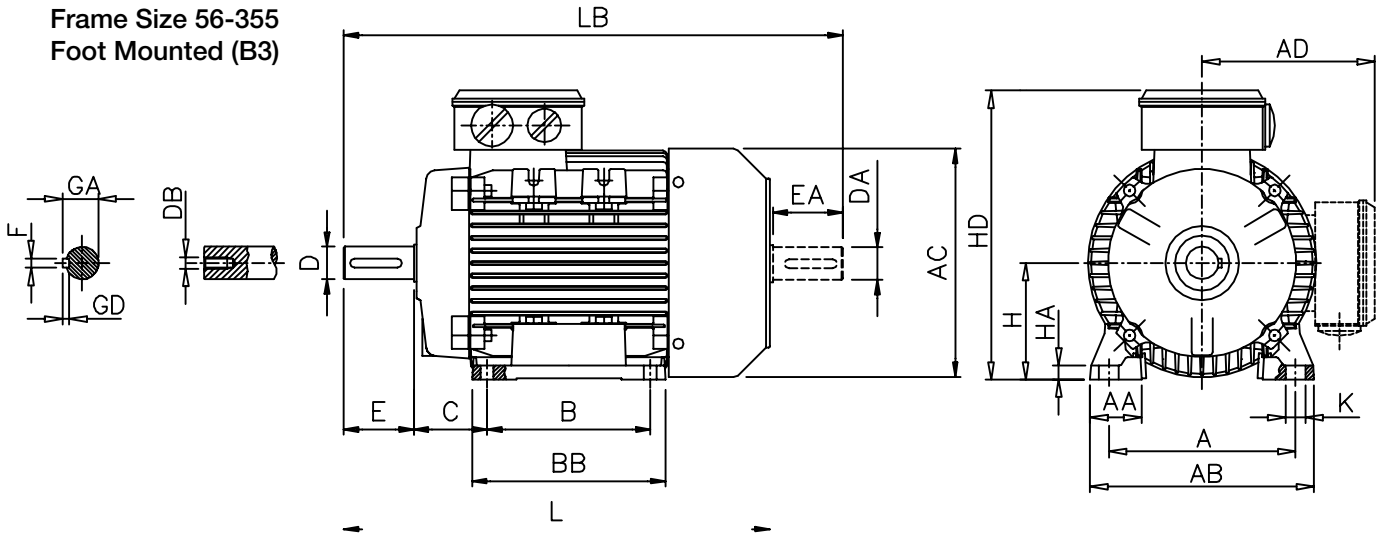

FRAME	NO OF POLES	H	A	B	C	K	AB	BB	AD	HD	AC	HA	L	LB	AA	D/DA	E/EA	F	GD	GA	DB
56	2-4	56	90	71	36	6.5	107	86	92.3	148.3	110	8	188	211	27	9	20	3	3	10.2	M3
63	2-4	63	100	80	40	7	135	100	117	180	120	8	225	251	30	11	23	4	4	12.5	M4
71	2-8	71	112	90	45	8	150	120	124	195	136	8	250	283	32	14	30	5	5	16	M5
80	2-8	80	125	100	50	10	153	125	134	219	156	9.5	295	338	35	19	40	6	6	21.5	M6
90S	2-8	90	140	100	56	10	180	130	160	250	176	12	315	368	36	24	50	8	7	27	M8
90L	2-8	90	140	125	56	10	180	155	160	250	176	12	340	393	36	24	50	8	7	27	M8
100L	2-8	100	160	140	63	12	205	176	170	270	196	14	385	448	40	28	60	8	7	31	M10
112M	2-8	112	190	140	70	12	230	180	188	300	220	15	400	463	45	28	60	8	7	31	M10
132S	2-8	132	216	140	89	12	270	230	213	345	259	18	470	553	55	38	80	10	8	41	M12
132M	2-8	132	216	178	89	12	270	238	213	345	259	18	510	593	55	38	80	10	8	41	M12
160M	2-8	160	254	210	108	15	320	260	260	420	315	20	615	728	65	42	110	12	8	45	M16
160L	2-8	160	254	254	108	15	320	304	260	420	315	22	670	783	65	42	110	12	8	45	M16
180M	2-8	180	279	241	121	15	355	316	270	455	355	22	740	853	70	48	110	14	9	51.5	M16
180L	2-8	180	279	279	121	15	355	316	270	455	355	22	740	853	70	48	110	14	9	51.5	M16
200L	2-8	200	318	305	133	19	395	369	341	541	397	30	770	883	70	55	110	16	10	59	M20
225S	2	225	356	311	149	18.5	420	375	360	585	445	30	860	973	90	55	110	16	10	59	M20
	4,6,8	225	356	311	149	19	435	368	360	585	445	28	890	1033	75	60	140	18	11	64	M20
225M	2	225	356	311	149	19	435	393	360	585	445	28	860	973	75	55	110	16	10	59	M20
	4,6,8	225	356	311	149	19	435	393	360	585	445	28	890	1033	75	60	140	18	11	64	M20
250M	2	250	406	349	168	24	490	445	390	640	495	30	910	1053	80	60	140	18	11	64	M20
	4,6,8	250	406	349	168	24	490	445	390	640	495	30	910	1053	80	65	140	18	11	69	M20
280S	2	280	457	368	190	24	550	485	565	680	547	35	985	1128	85	65	140	18	11	69	M20
	4,6,8	280	457	368	190	24	550	485	565	680	547	35	985	1128	85	75	140	20	12	79.5	M20
280M	2	280	457	419	190	24	550	536	410	680	547	35	1035	1178	85	65	140	18	11	69	M20
	4,6,8	280	457	419	190	24	550	536	410	680	547	35	1035	1178	85	75	140	20	12	79.5	M20
315S	2	315	508	406	216	28	635	570	695	845	620	45	1178	1321	120	65	140	18	11	69	M20
	4,6,8,10	315	508	406	216	28	635	570	695	845	620	45	1208	1381	120	80	170	22	14	85	M20
315M	2	315	508	457	216	28	635	680	695	845	620	45	1288	1431	120	65	140	18	11	69	M20
	4,6,8,10	315	508	457	216	28	635	680	695	845	620	45	1318	1491	120	80	170	22	14	85	M20
315L	2	315	508	508	216	28	635	680	695	845	620	45	1288	1431	120	65	140	18	11	69	M20
	4,6,8,10	315	508	508	216	28	635	680	695	845	620	45	1318	1491	120	80	170	22	14	85	M20
355M	2	355	610	560	254	28	730	760	655	1010	698	52	1496	1639	116	75	140	20	12	79.5	M20
	4,6,8,10	355	610	560	254	28	730	760	655	1010	698	52	1536	1709	116	95	170	25	14	100	M20
355L	2	355	610	630	254	28	730	760	655	1010	698	52	1496	1639	116	75	140	20	12	79.5	M20
	4,6,8,10	355	610	630	254	28	730	760	655	1010	698	52	1536	1709	116	95	170	25	14	100	M20

Frame Size 56-355  
Flange Mounted (B5)

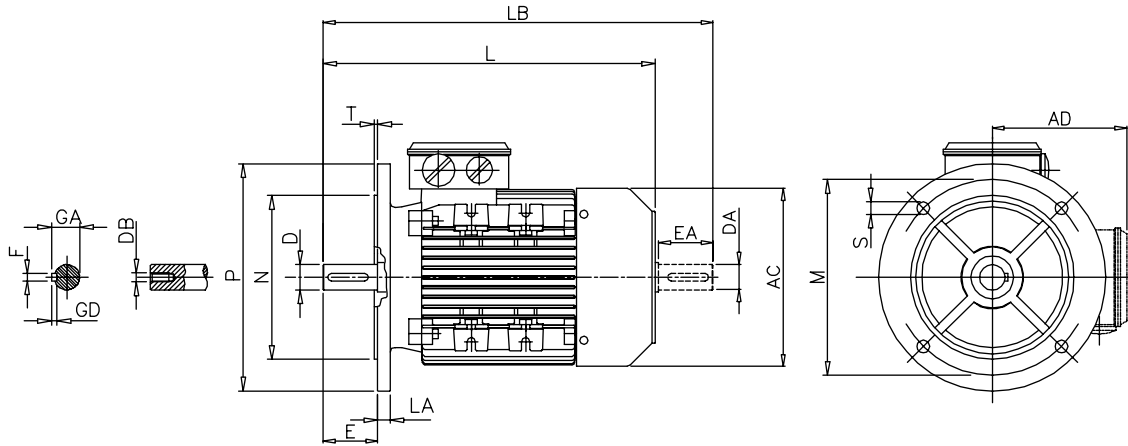

FRAME	NO OF POLES	P	N	LA	M	T	S	NO OF HOLES	D/DA	E/EA	F	GD	GA	DB	AC	L	LB	AD
56	2-4	120	80	6.9	100	2.5	7*	4	9	20	3	3	10.2	M3	110	188	211	93
63	2-4	140	95	8	115	3	9.5*	4	11	23	4	4	12.5	M4	120	225	251	117
71	2-8	160	110	10	130	3.5	9.5*	4	14	30	5	5	16	M5	136	250	283	124
80	2-8	200	130	10	165	3.5	11.5*	4	19	40	6	6	21.5	M6	156	295	338	134
90S	2-8	200	130	12	165	3.5	12	4	24	50	8	7	27	M8	176	315	368	160
90L	2-8	200	130	12	165	3.5	12	4	24	50	8	7	27	M8	176	340	393	160
100L	2-8	250	180	13	215	4	15	4	28	60	8	7	31	M10	196	385	448	170
112M	2-8	250	180	14	215	4	15	4	28	60	8	7	31	M10	220	400	463	188
132S	2-8	300	230	14	265	4	15	4	38	80	10	8	41	M12	259	470	553	213
132M	2-8	300	230	14	265	4	15	4	38	80	10	8	41	M12	259	510	593	213
160M	2-8	350	250	15	300	5	19	4	42	110	12	8	45	M16	315	615	728	260
160L	2-8	350	250	15	300	5	19	4	42	110	12	8	45	M16	315	670	783	260
180M	2-8	350	250	13	300	5	18	4	48	110	14	9	51.5	M16	355	740	853	270
180L	2-8	350	250	13	300	5	18	4	48	110	14	9	51.5	M16	355	740	853	270
200L	2-8	400	300	15	350	5	18	8	55	110	16	10	59	M20	397	770	883	341
225S	2	450	350	16	400	5	18	8	55	110	16	10	59	M20	445	860	973	360
	4,6,8	450	350	16	400	5	18	8	60	140	18	11	64	M20	445	890	1033	360
225M	2	450	350	16	400	5	18	8	55	110	16	10	59	M20	445	860	973	360
	4,6,8	450	350	16	400	5	18	8	60	140	18	11	64	M20	445	890	1033	360
250M	2	550	450	18	500	5	18	8	60	110	18	11	64	M20	495	910	1023	390
	4,6,8	550	450	18	500	5	18	8	65	140	18	11	69	M20	495	910	1053	390
280S	2	550	450	22	500	5	19	8	65	140	18	11	69	M20	547	985	1128	410
	4,6,8	550	450	22	500	5	19	8	75	140	20	12	79.5	M20	547	985	1128	410
280M	2	550	450	22	500	5	19	8	65	140	18	11	69	M20	547	1035	1178	410
	4,6,8	550	450	22	500	5	19	8	75	140	20	12	79.5	M20	547	1035	1178	410
315S	2	660	550	22	600	6	24	8	65	140	18	11	69	M20	620	1178	1321	530
	4,6,8,10	660	550	22	600	6	24	8	80	170	22	14	85	M20	620	1208	1381	530
315M	2	660	550	22	600	6	24	8	65	140	18	11	69	M20	620	1288	1431	530
	4,6,8,10	660	550	22	600	6	24	8	80	170	22	14	85	M20	620	1318	1491	530
315L	2	660	550	22	600	6	24	8	65	140	18	11	69	M20	620	1288	1431	530
	4,6,8,10	660	550	22	600	6	24	8	80	170	22	14	85	M20	620	1318	1491	530
355M	2	800	680	25	740	6	24	8	75	140	20	12	79.5	M20	698	1496	1639	655
	4,6,8,10	800	680	25	740	6	24	8	95	170	25	14	100	M20	698	1536	1709	655
355L	2	800	680	25	740	6	24	8	75	140	20	12	79.5	M20	698	1496	1639	655
	4,6,8,10	800	680	25	740	6	24	8	95	170	25	14	100	M20	698	1536	1709	655

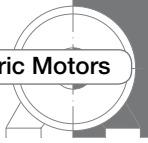

Frame Size 56-160  
Face Mounted (B14)

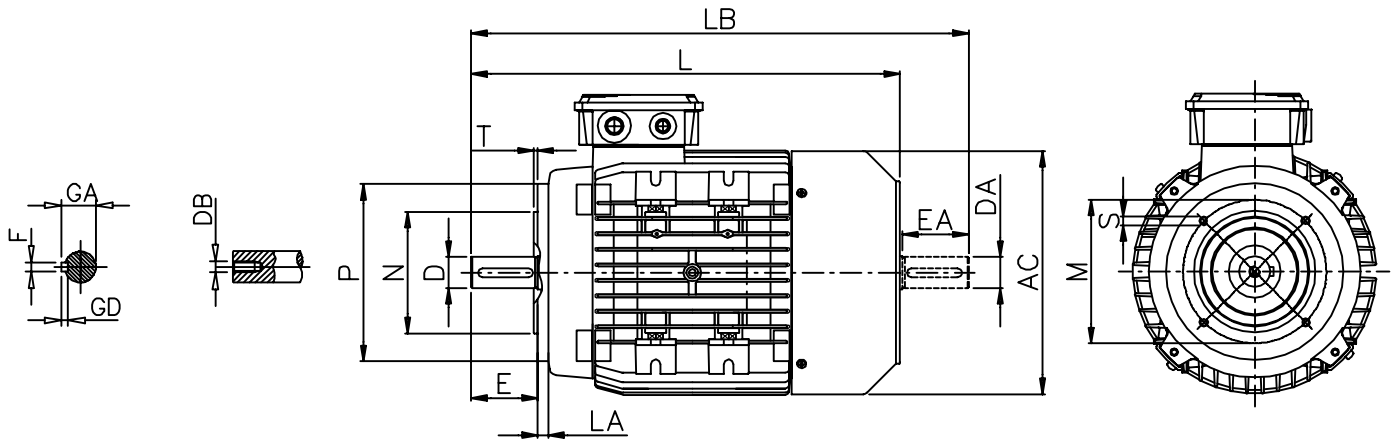

FRAME	NO OF POLES	P	N	LA	M	T	S	D/DA	E/EA	GD	GA	DB	AC	L	LB	AD
56	2-4	80	50	8	65	2.5	M5	9	20	3	10.2	M3	110	188	211	92.3
63	2-4	90	60	8.5	75	2.5	M5	11	23	4	12.5	M4	123	211	237	96.5
71	2-8	105	70	7.6	85	2.5	M6	14	30	5	16	M5	139	246	279	111
80	2-8	120	80	9.5	100	3	M6	19	40	6	21.5	M6	155.6	273	316	139
90S	2-8	140	95	9	115	3	M8	24	50	7	27	M8	176	317.5	370.5	148
90L	2-8	140	95	9	115	3	M8	24	50	7	27	M8	176	317.5	370.5	148
100L	2-8	160	110	10	130	3.5	M8	24	60	7	31	M10	196	366.5	429.5	155
112M	2-8	160	110	10	130	3.5	M8	28	60	7	31	M10	220	387	450	171
132S	2-8	200	130	23	165	3.5	M10	38	80	8	41	M12	248	443.5	526.5	195
132M	2-8	200	130	23	165	3.5	M10	38	80	8	41	M12	248	483	566	195
132M	2-8	200	130	23	165	3.5	M10	38	80	8	41	M12	248	500	583	195
160M	2-8	250	180	20	215	4	M12	42	110	8	45	M16	317	610	723	241
160L	2-8	250	180	20	215	4	M12	42	110	8	45	M16	317	654	767	241





TERMINAL BOX DRAWING

Frame 56-71 (Nylon)

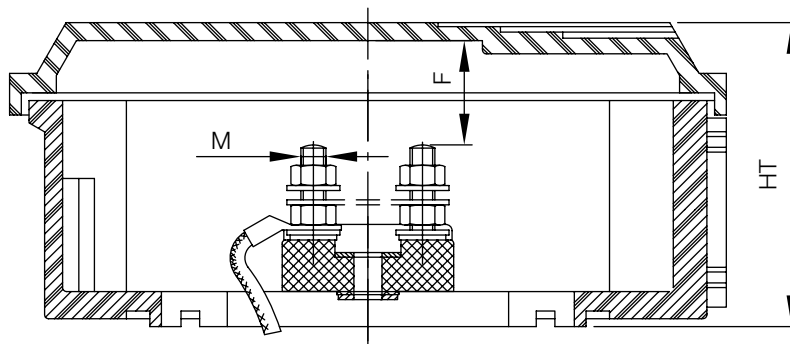
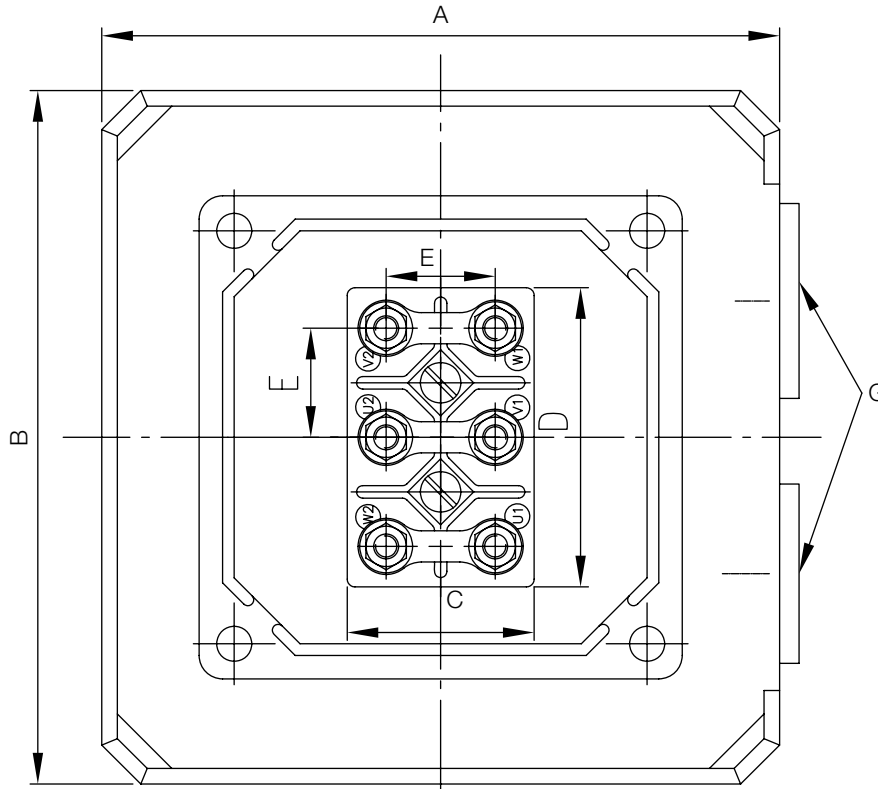

Frame	A	B	C	D	E	F	G	HT	M
56(AL)	90	92	25	40	15	10	M16, M20	40	M4
63(AL)	90	92	25	40	15	10	M16, M20	40	M4
71(AL)	90	92	25	40	15	10	M16, M20	40	M4

1. All Dimensions are in mm 2. Degree of Protection IP55

## TERMINAL BOX DRAWING

T-BOX DIMENSIONS(80-160 FRAME) Aluminium

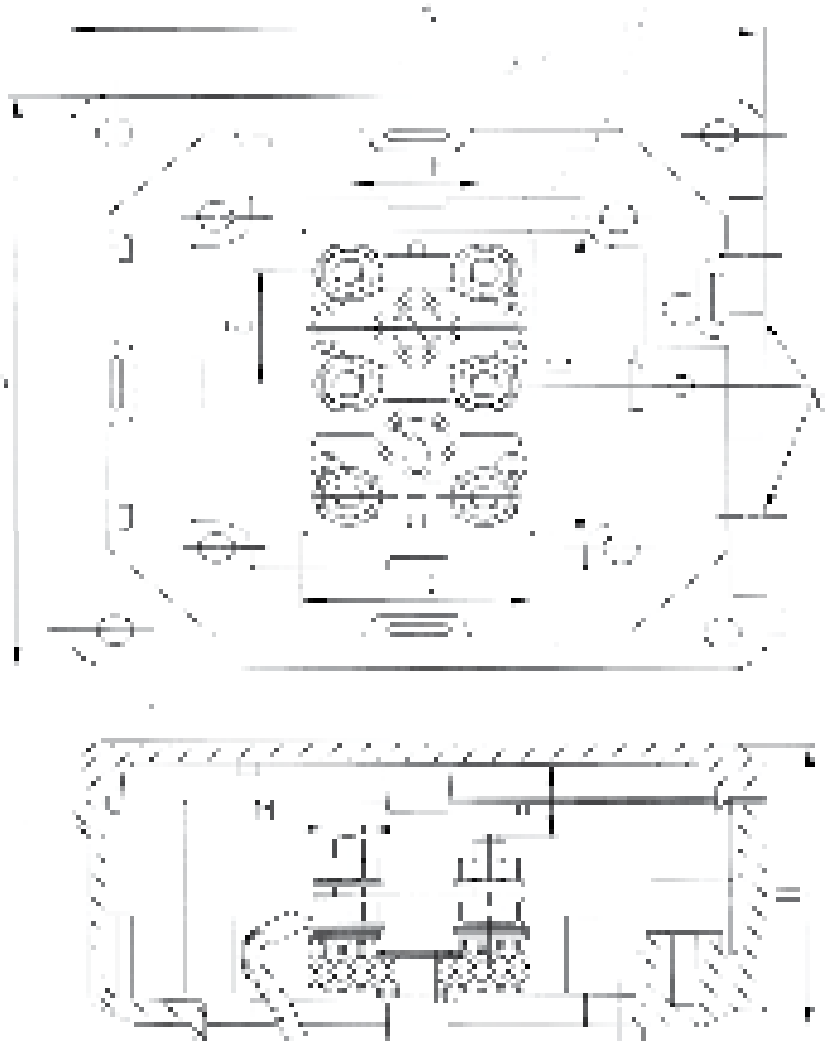

FRAME	A	B	C	D	E	F	G	HT	M
80	111	116	25	40	15	20	M20, M25	55	M4
90	101	101	36	56	25	10	M25	59	M5
100	108	101	36	56	25	12	M32,M32	59	M5
112	116	108	36	56	25	15	M32,M32	64	M5
132	116	108	40	64	25	15	M32,M32	64	M5
160	159	149	50	85	30	12	M40,M40	78	M6

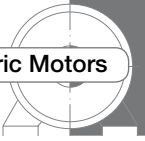

## TERMINAL BOX DRAWING

Frame 160-250 (Sheet Metal)

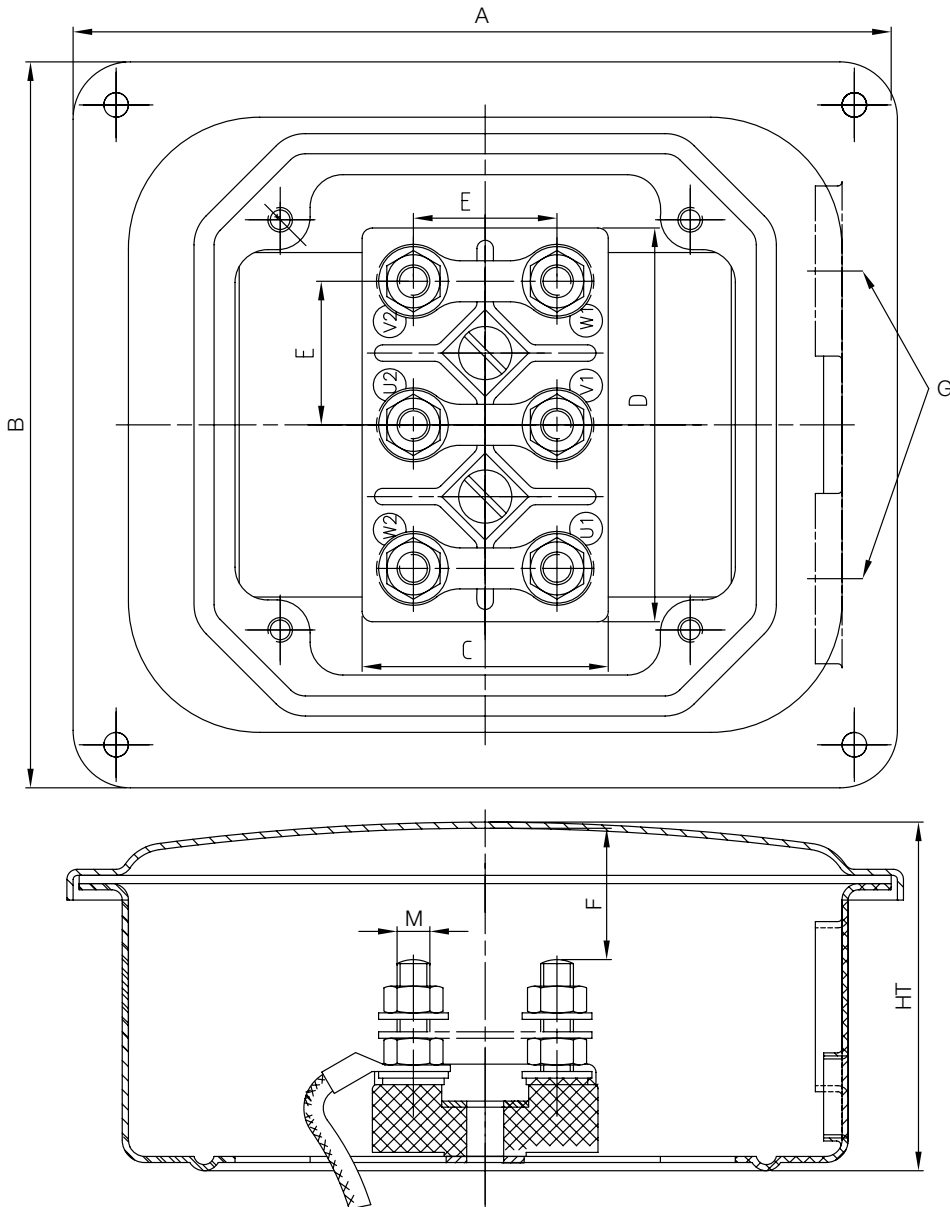

Frame	A	B	C	D	E	F	G	HT	M
160 (Cl)	204	180	52	82	30	30	M40, M40	85	M6
180 (Cl)	204	180	60	96	35	30	M40, M40	85	M8
200 (Cl)	258	265	60	96	35	70	M50, M50	132	M8
225 (Cl)	258	265	75	120	45	70	M50, M50	132	M10
250 (Cl)	258	265	75	120	45	70	M50/M63, M50/M63	132	M10

1. All Dimensions are in mm 2. Degree of Protection IP55

## TERMINAL BOX DRAWING

Frame 250-280 (Cast Iron)

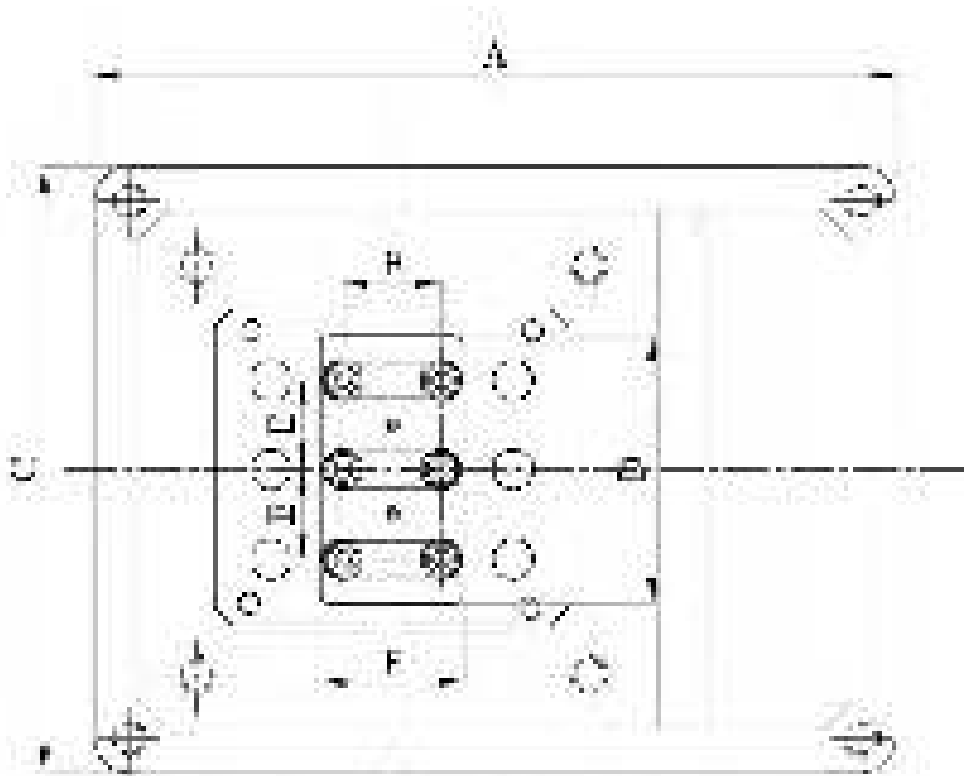

VIEW WITH TERMINAL BOX COVER

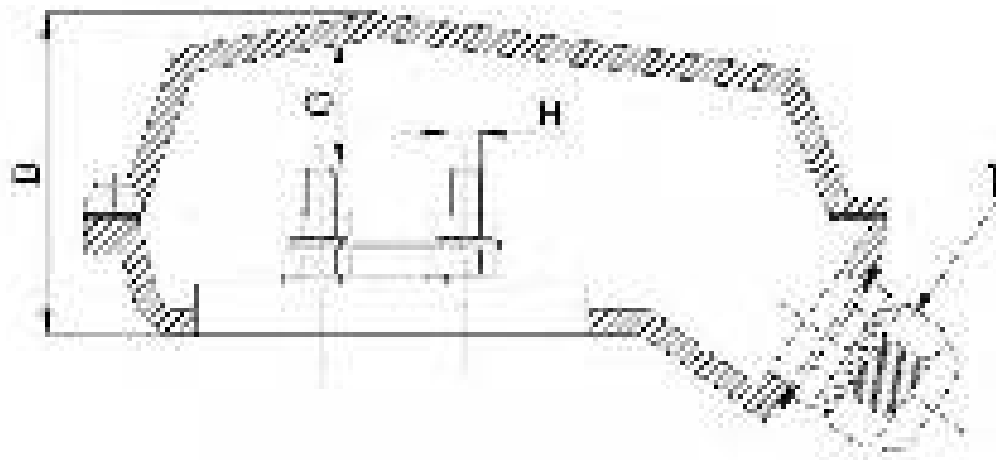

Frame	A	B	C	D	E	F	G	H	I
250	342	135	230	140	50	85	40	M10	M63, M63
280	342	165	230	140	50	85	40	M10	M63, M63

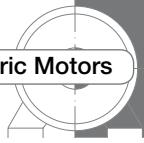

### TERMINAL BOX DRAWING

#### Frame 315 - 355 Cast / Iron

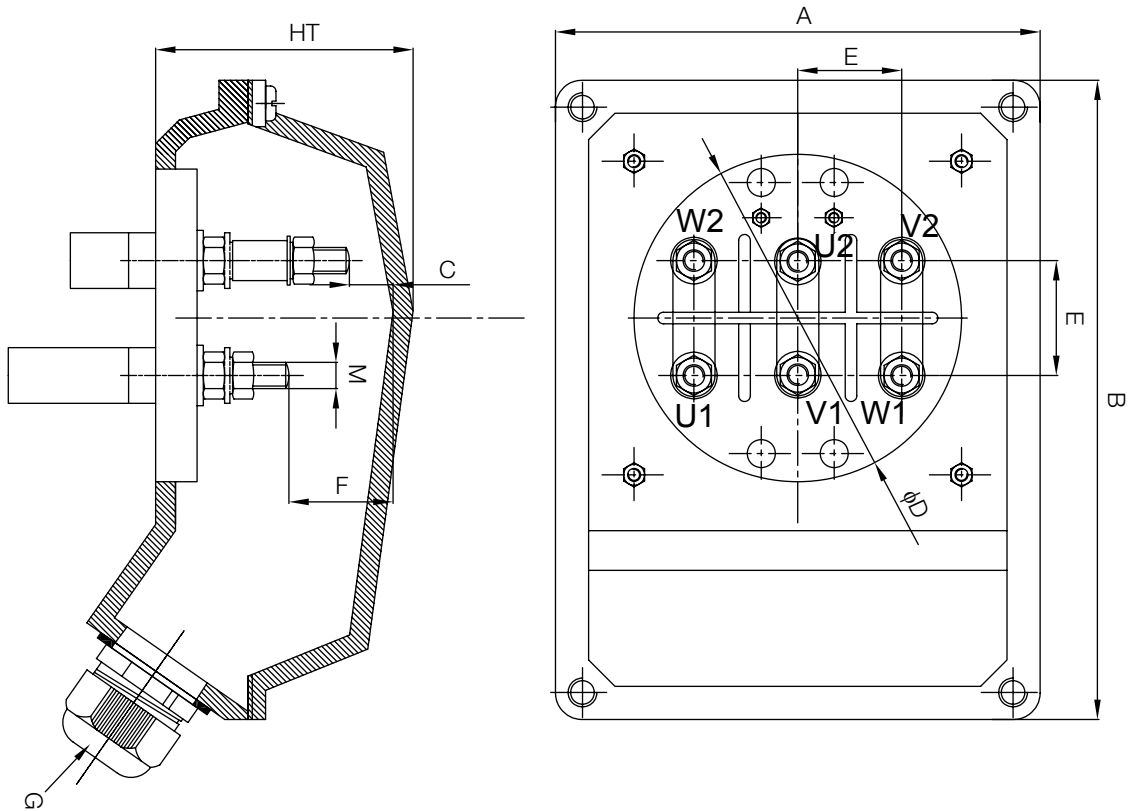

Frame	A	B	C	D	E	F	G	HT	M
315	280	390	25	φ210	70	45	2 X M63 X 1.5	140	M16
355	374	484	30	φ260	90	75	2 X M63 X 1.5	195	M20



## Other Products

### Building Circuit Protection



### Compact Fluorescent Lamp (CFL)



### Luminaires

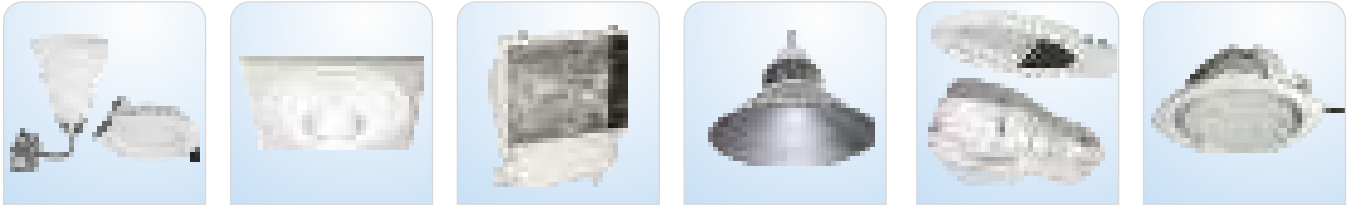

### Fans & Domestic Appliances

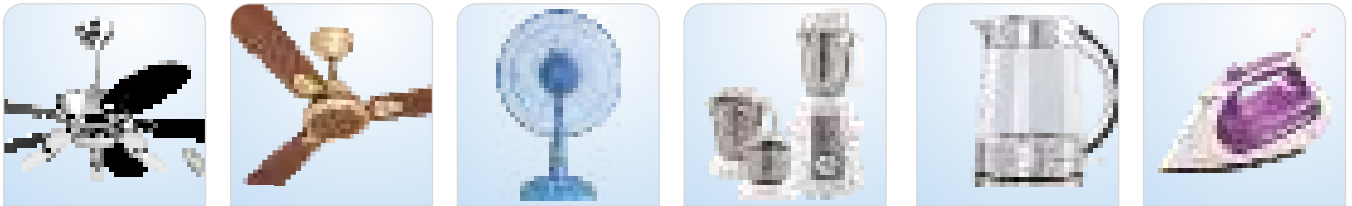

### Power & Flexible Cables



### Industrial Circuit Protection



### APFC & IPFC

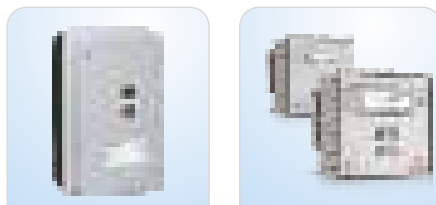

### Capacitors

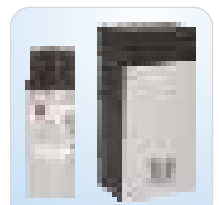

### Switches



View of Motor Manufacturing Plant



Automatic Winding



CNC Machine



Painting Line

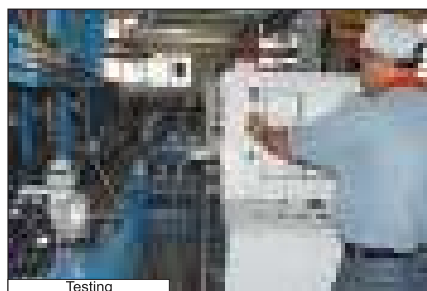

Testing

Regional & Branch Offices:

**NORTH - REGIONAL OFFICE:** Corporate Office: QRG Towers, 2D, Sector-126, Expressway, Noida-201304, Tel: 0120-4771000, Delhi: Tel: 011-47676700, 23888200, Chandigarh: Tel: 0172-4232400-401, Dehradun: Tel: 0135-6670202, Noida / Haryana: Tel: 0120-4771000, Ludhiana: Tel: 0161-4676001 / 6024, Jammu: Tel: 0191-2490424, Sri Nagar: Tel: 0194-2490431, Jaipur: Tel: 0141-3988210, Jodhpur: Tel: 0141-3914645, 3988210, Lucknow: Tel: 0522-2201032, 2200938, Kanpur: Tel: 0512-6710400, 9935533753 **EAST - REGIONAL OFFICE:** Kolkata: ICC Tower, 5th Floor, 4 India Exchange Place, Kolkata-700001, Tel: 033-40129851 / 52, Bhubaneswar: Tel: 0674-6668101/102/103/104, Guwahati: Tel: 0361-2134521, 2458923, Siliguri: Tel: 0353-2525907, Jamshedpur: Tel: 0657-6542492, 09234369436, Patna: Tel: 0612-2207221, 2207222, 2207223, 2655518 **WEST - REGIONAL OFFICE:** Mumbai: 301, Everest House, 3rd Floor, 6, Suren Road, Chakala, Andheri (E). Mumbai - 400 093, Tel: 022-67298600-602, Ahmedabad: Tel: 079-40061111, 40060738-740, Indore: Tel: 0731-2572340-41, 4009998 (Airtel), Rajkot: Tel: 0281-2481112, 2921212, Nagpur: Tel: 0712-2240932, 2242692, 2242699 Pune: Tel: 020-64016413 / 14, Raipur: Tel: 0771-4243400 / 01, Surat: Tel: 0261-2350137, 9979890137, Jabalpur: Tel: 0761-4064491 **SOUTH - REGIONAL OFFICE:** Chennai: Sigapi Achi Building, No. 18 / 3, 6th Floor, Rukmani Lakshmi pathy Road, Egmore, Chennai-600008, Tel: 044-42280600, 605, Bangalore: Tel: 080-49075000, 9844085913, Coimbatore: Tel: 0422-2305767, 2306199, 2305199, Hyderabad: Tel: 040-27533372, 27533355, 27533632, 66320407/0408/6401/6402, Kochi: Tel: 0484-4099000, Vishakapatnam: Tel: 0891-6514339, Vizag: Tel: 0891-6514339, Vijayawada: Tel: 91+9247058847/57, Calicut: 09895855499, Madurai: 09994493242, Trivandrum: 09633817795, Hubli: 09448146028, Trichy: 09944460160

Representative Offices: • Goa • Solapur • Gwalior • Kathmandu • Bhopal

Although every effort has been made to ensure accuracy in the compilation of the technical detail within this publication, specifications and performance data are constantly changing. Current details should therefore be checked with Havells Group.

**Havells India Ltd.**

Corp Office: QRG Towers, 2D, Sector-126, Expressway, Noida-201304 (U.P), Ph.+91-120-4771000,  
E-mail: marketing@havells.com, www.havells.com  
Consumer Care No.: 1800 11 0303, 1800 103 1313 (All Connections), 011-4166 0303 (Landline)  
Join us on Facebook at [www.facebook.com/havells](http://www.facebook.com/havells) and share your ways to save the planet!





IE2 & IE3  
Energy Efficient  
3 Phase  
LV Induction Motors



Prima Series

CE (IE2) & (IE3)

**HAVELLS-LAFERT** MOTORS



# Prima Series

## IE2 & IE3 Motors

Havells is the first in India to introduce complete range of IE2, IE3 Efficiency Motors



### Overview

The New Standard IEC60034-30/IS12615:2011 defines and harmonizes worldwide the IE efficiencies classes for low-voltage three-phase cage Induction motors.

The IE Efficiency classes defined as:

IE1-Standard Efficiency (Comparable to EFF2)

IE2-High Efficiency (Comparable to EFF1)

IE3 – Premium Efficiency

The efficiencies required by the new standards can only be achieved by the increased use of active and higher quality of materials and more complexity production technique etc. Hence purchase price of motor will increase accordingly.

### What is IE?

IE is "International Efficiency" with class 1, 2 & 3 i.e. IE1 & IE2 & IE3. The new standard IEC 60034-30: 2008 & IS12615:2011 defines these classes. At the same time, with the IEC 60034-2-1: 2007 standard, a new procedure for the determination of efficiency has been introduced which also contributes to international harmonization. This standard is made to unify motor testing procedure, determination of efficiency and product labeling requirements. This is to enable motor user worldwide to easily identify premium efficiency products.

### Need of Improved Efficiency

Over 70% of all electrical energy consumed in industries is used by the motors, hence improving the efficiency of electric motors can save energy as well as operating cost, which is more than its purchase cost.



The New Efficiency classes and its equivalence with other nomenclature is given as below:

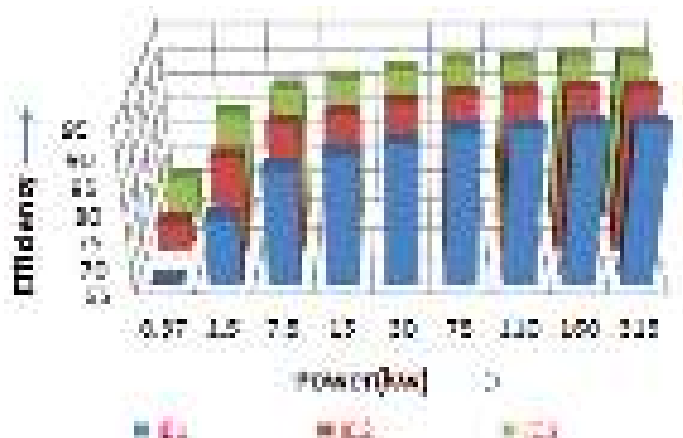
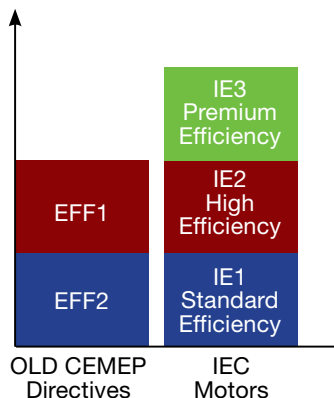



### Method of testing Efficiency

In addition to the new nomenclature, the measuring technique has also changed. The efficiency levels according to EN 60034-30 are measured with the new method stipulated in EN 60034-2-1. The Stray load losses are no longer assumed to be sum of 0.5%; instead, they are determined by making measurements.

This new method for IE motors helps to generate more exact data regarding stray load loss and will show a reduction in the measured efficiency level for the motor. Thus for a

The New IS 21615: 2011 is applicable for three-phase, 50Hz, single speed & Squirrel cage induction motors.

Havells range of motors have the following specification:

• Voltage	:	Rated voltage ≤1000V
• Output	:	Rated output 0.37kW to 315kW
• No of Poles	:	2, 4 or 6 poles
• Frame Dimensions	:	Meet frame size to output relation as covered in IS: 1231
• Ambient Temperature	:	Designed for an ambient temperature not exceeding 50°C and altitude not exceeding 1000
• Balance Voltage	:	Designed for operation on virtually sinusoidal and balanced Voltage conditions as defined in 7.2.1 of IS/IEC 60034-1
• Degree of protection	:	Degree of protection IP55
• Cooling Method	:	Method of cooling IC411 in accordance with IS 6362/IEC 60034-6

given efficiency, an IE2 motor will need to have more active material as compared to EFF1 motor to compensate for the increase in measured losses.

### Havells IE2 & IE3 motors conform to IS 12615:2011 and IEC 60034-30:2008

- Suitable for continuous process industries, where high energy saving is essential.
- Short Payback Period.
- Enhanced motor life.
- Less maintenance.

### Cost effectiveness:

Saving concluded as follows:

kW = Output of motor

IE1 = Efficiency of IE1 motors

IE2 = Efficiency of IE2 motors

PD = Price Difference between two efficiencies;

$$X = \frac{\text{kW}}{\text{IE1}} - \frac{\text{kW}}{\text{IE2}}$$

**Saving** = (X x Working hrs x Working days x Tariff x 100)

**Payback Period** = (PD/Saving) x 12 months

### Special Application

The major benefit to use these motors are in continuous duty application like Cement, textiles, blowers, compressors, fans & pumps etc.



kW	2-Pole			4 Pole			6 Pole		
	Frame Size	Efficiency %		Frame Size	Efficiency %		Frame Size	Efficiency %	
		IE2	IE3		IE2	IE3		IE2	IE3
0.37	71	72.2	75.5	71	70.1	73	80	69	71.9
0.55	71	74.8	78.1	80	75.1	78	80	72.9	75.9
0.75	80	77.4	80.7	80	79.6	82.5	90S	75.9	78.9
1.1	80	79.6	82.7	90S	81.4	84.1	90L	78.1	81
1.5	90S	81.3	84.2	90L	82.8	85.3	100L	79.8	82.5
2.2	90L	83.2	85.9	100L	84.3	86.7	112M	81.8	84.3
3.7	100L	85.5	87.8	112M	86.3	88.4	132S	84.3	86.5
5.5	132S	87	89.2	132S	87.7	89.6	132M	86	88
7.5	132S	88.1	90.1	132M	88.7	90.4	160M	87.2	89.1
11	160M	89.4	91.2	160M	89.8	91.4	160L	88.7	90.3
15	160M	90.3	91.9	160L	90.6	92.1	180L	89.7	91.2
18.5	160L	90.9	92.4	180M	91.2	92.6	200L	90.4	91.7
22	180M	91.3	92.7	180L	91.6	93	200L	90.9	92.2
30	200L	92	93.3	200L	92.3	93.6	225M	91.7	92.9
37	200L	92.5	93.7	225S	92.7	93.9	250M	92.2	93.3
45	225M	92.9	94	225M	93.1	94.2	280S	92.7	93.7
55	250M	93.2	94.3	250M	93.5	94.6	280M	93.1	94.1
75	280S	93.8	94.7	280S	94	95	315S	93.7	94.6
90	280M	94.1	95	280M	94.2	95.2	315M	94	94.9
110	315S	94.3	95.2	315S	94.5	95.4	315M	94.3	95.1
125	315M	94.5	95.3	315M	94.6	95.5	315M	94.4	95.2
132	315M	94.6	95.4	315M	94.7	95.6	315L	94.6	95.4
160	315L	94.8	95.6	315L	94.9	95.8	355M	94.8	95.6
200	315L	95	95.8	315L	95.1	96	355M	95	95.8
250	355M	95	95.8	355M	95.1	96	355L	95	95.8
315	355L	95	95.8	355L	95.1	96	355L	95	95.8

Regional & Branch Offices:

**NORTH - REGIONAL OFFICE:** Corporate Office: QRG Towers, 2D, Sector-126, Expressway, Noida-201304, Tel: 0120-4771000, Delhi: Tel: 011-47676700, 23888200, Chandigarh: Tel: 0172-4232400-401, Dehradun: Tel: 0135-6670202, Noida / Haryana: Tel: 0120-4771000, Ludhiana: Tel: 0161-4676001 / 6024, Jammu: Tel: 0191-2490424, Sri Nagar: Tel: 0194-2490431, Jaipur: Tel: 0141-3988210, Jodhpur: Tel: 0141-3914645, 3988210, Lucknow: Tel: 0522-2201032, 2200938, Kanpur: Tel: 0512-6710400, 9935533753

**EAST - REGIONAL OFFICE:** Kolkata: ICC Tower, 5th Floor, 4 India Exchange Place, Kolkata-700001, Tel: 033-40129851 / 52, Bhubaneswar: Tel: 0674-6668101/102/103/104, Guwahati: Tel: 0361-2134521, 2458923, Siliguri: Tel: 0353-2525907, Jamshedpur: Tel: 0657-6542492, 09234369436, Patna: Tel: 0612-2207221, 2207222, 2207223, 2655518

**WEST - REGIONAL OFFICE:** Mumbai: 301, Everest House, 3rd Floor, 6, Suren Road, Chakala, Andheri (E), Mumbai - 400 093, Tel: 022-67298600-602, Ahmedabad: Tel: 079-40061111, 40060738-740, Indore: Tel: 0731-2572340-41, 4009998 (Airtel), Rajkot: Tel: 0281-2481112, 2921212, Nagpur: Tel: 0712-2240932, 2242692, 2242699 Pune: Tel: 020-64016413 / 14, Raipur: Tel: 0771-4243400 / 01, Surat: Tel: 0261-2350137, 9979890137, Jabalpur: Tel: 0761-4064491

**SOUTH - REGIONAL OFFICE:** Chennai: Sigapi Achi Building, No. 18 / 3, 6th Floor, Rukmani Lakshmi pathy Road, Egmore, Chennai-600008, Tel: 044-42280600, 605, Bangalore: Tel: 080-49075000, 9844085913, Coimbatore: Tel: 0422-2305767, 2306199, 2305199, Hyderabad: Tel: 040-27533372, 27533355, 27533632, 66320407/0408/6401/6402, Kochi: Tel: 0484-4099000, Vishakapatnam: Tel: 0891-6514339, Vizag: Tel: 0891-6514339, Vijayawada: Tel: 91+9247058847/57, Calicut: 09895855499, Madurai: 09994493242, Trivandrum: 09633817795, Hubli: 09448146028, Trichy: 09944460160

Representative Offices: • Goa • Solapur • Gwalior • Kathmandu • Bhopal

**Havells India Ltd.**

Corp Office: QRG Towers, 2D, Sector-126, Expressway, Noida-201304 (U.P), Ph.+91-120-4771000,  
E-mail: marketing@havells.com, www.havells.com  
Consumer Care No.: 1800 11 0303, 1800 103 1313 (All Connections), 011-4166 0303 (Landline)  
Join us on Facebook at www.facebook.com/havells and share your ways to save the planet!



**HAVELLS**